



US008575641B2

(12) **United States Patent**
Zimmerman et al.

(10) **Patent No.:** **US 8,575,641 B2**
(45) **Date of Patent:** **Nov. 5, 2013**

(54) **SOLID STATE LIGHT SOURCES BASED ON THERMALLY CONDUCTIVE LUMINESCENT ELEMENTS CONTAINING INTERCONNECTS**

(75) Inventors: **Scott M. Zimmerman**, Basking Ridge, NJ (US); **William R. Livesay**, San Diego, CA (US); **Richard L. Ross**, Del Mar, CA (US); **Eduardo DeAnda**, San Diego, CA (US)

(73) Assignee: **Goldeneye, Inc**, San Diego, CA (US)

(*) Notice: Subject to any disclaimer, the term of this patent is extended or adjusted under 35 U.S.C. 154(b) by 0 days.

(21) Appl. No.: **13/572,608**

(22) Filed: **Aug. 10, 2012**

(65) **Prior Publication Data**
US 2013/0099264 A1 Apr. 25, 2013

Related U.S. Application Data

(60) Provisional application No. 61/574,925, filed on Aug. 11, 2011.

(51) **Int. Cl.**
H01L 33/64 (2010.01)

(52) **U.S. Cl.**
USPC 257/98; 257/E33.075

(58) **Field of Classification Search**
USPC 257/98, E33.075
See application file for complete search history.

(56) **References Cited**

U.S. PATENT DOCUMENTS

4,421,671	A	12/1983	Cusano et al.	
4,466,930	A	8/1984	Greskovich et al.	
4,849,639	A	7/1989	Born et al.	
6,565,770	B1	5/2003	Mayer et al.	
6,630,691	B1	10/2003	Mueller-Mach et al.	
6,667,574	B2	12/2003	Aoki et al.	
6,696,703	B2	2/2004	Mueller-Mach et al.	
7,285,791	B2	10/2007	Beeson et al.	
7,422,801	B2*	9/2008	Yamashita	257/611
7,804,099	B2	9/2010	Beeson et al.	
7,855,449	B2*	12/2010	De Graff et al.	257/98
2005/0006659	A1	1/2005	Ng et al.	
2006/0284190	A1	12/2006	Zimmerman et al.	

OTHER PUBLICATIONS

J. R. Grammer, "Emissivity Coatings for Low-Temperature Space Radiators", NASA Contract NAS-3-7630, Sep. 30, 1966.

* cited by examiner

Primary Examiner — Chandra Chaudhari
(74) *Attorney, Agent, or Firm* — William Propp, Esq

(57) **ABSTRACT**

Solid state light sources based on LEDs mounted on or within thermally conductive luminescent elements provide both convective and radiative cooling. Low cost self-cooling solid state light sources can integrate the electrical interconnect of the LEDs and other semiconductor devices. The thermally conductive luminescent element can completely or partially eliminate the need for any additional heatsinking means by efficiently transferring and spreading out the heat generated in LED and luminescent element itself over an area sufficiently large enough such that convective and radiative means can be used to cool the device.

46 Claims, 21 Drawing Sheets

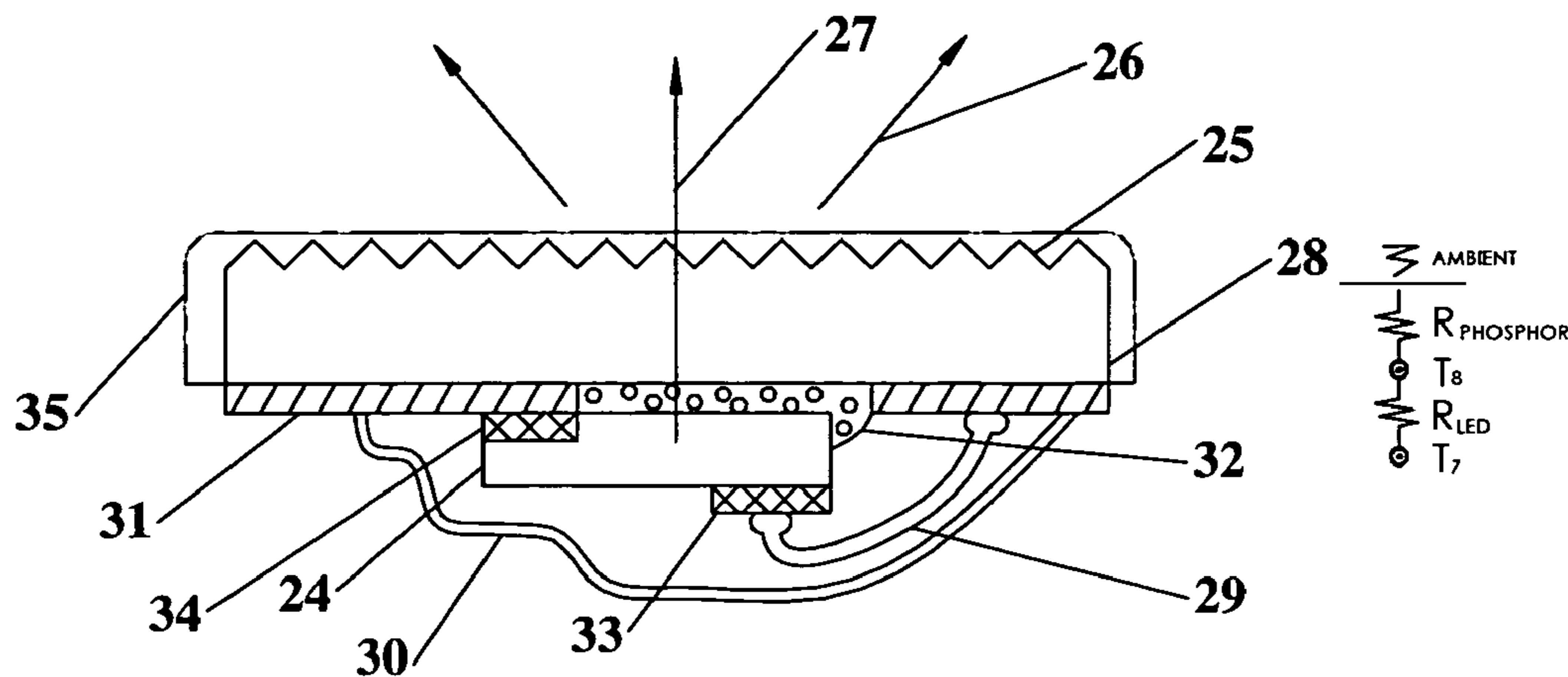

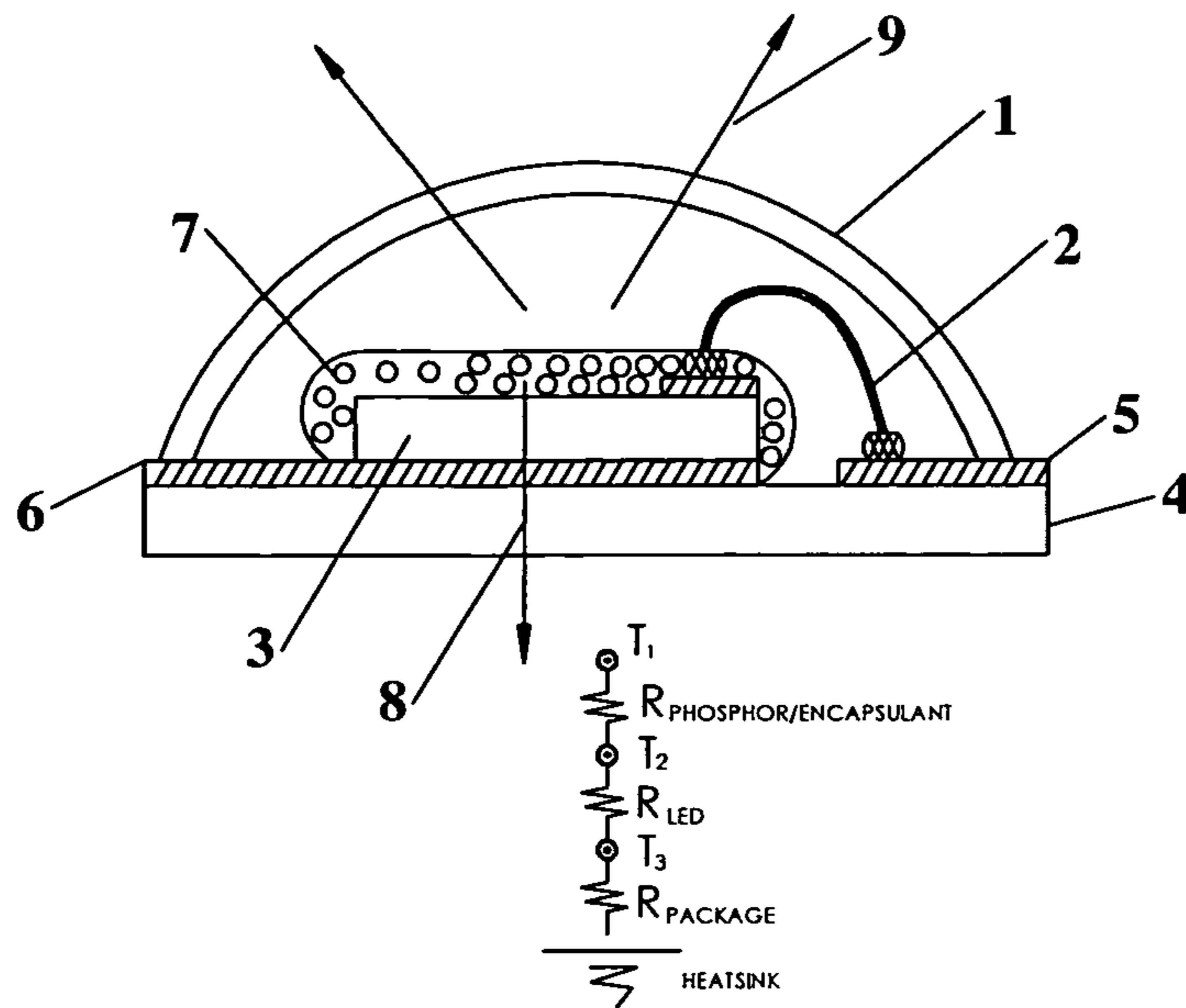

FIG. 1A
(Prior Art)

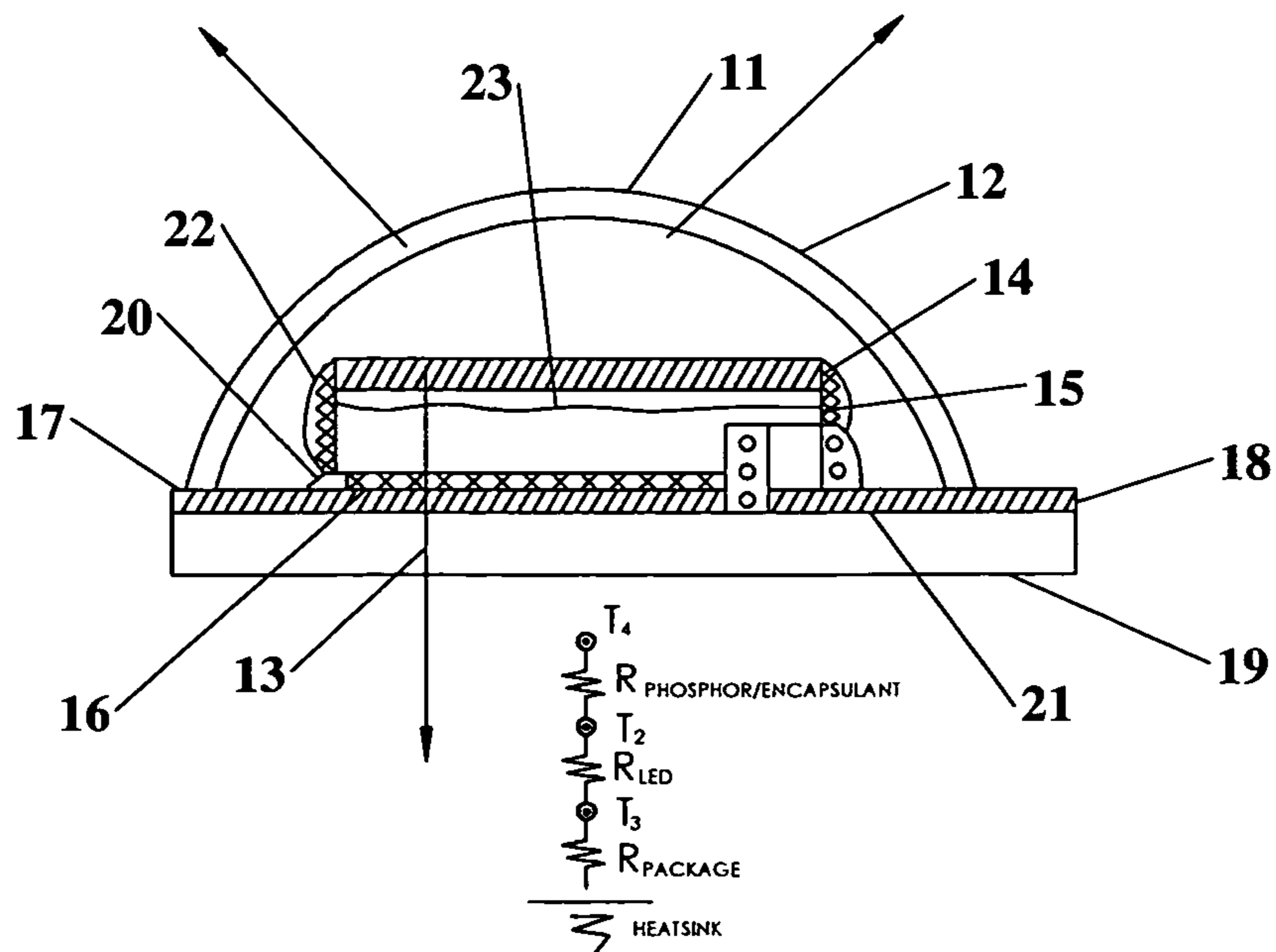

FIG. 1B
(Prior Art)

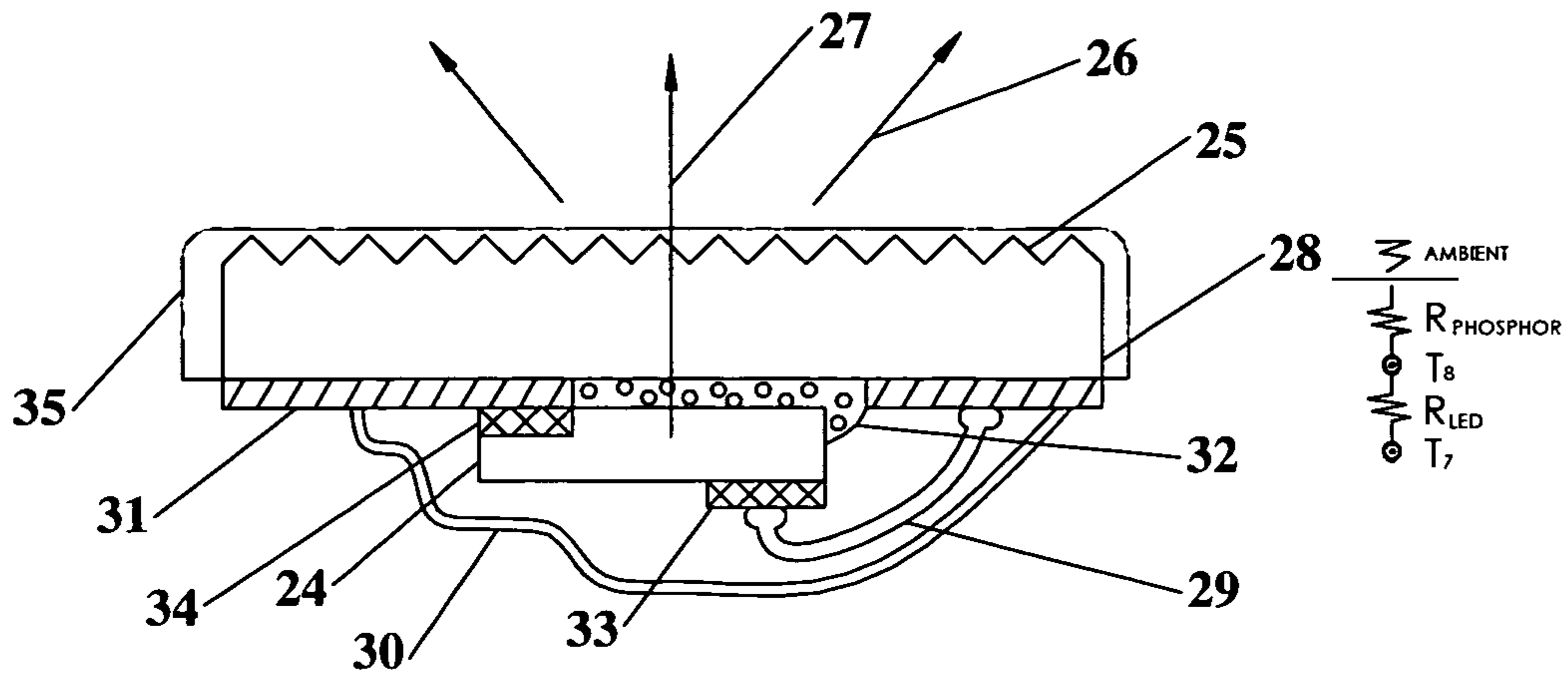

FIG. 2A

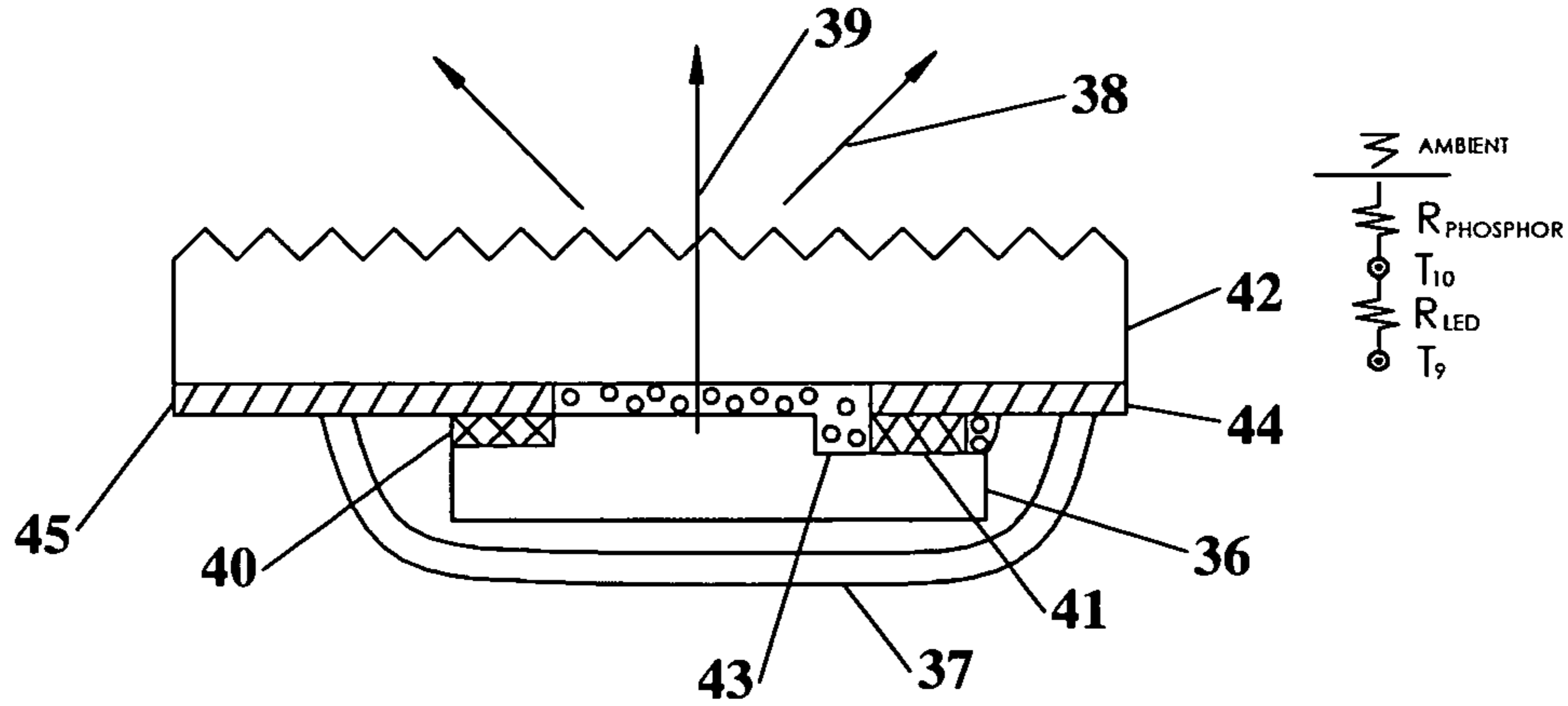

FIG. 2B

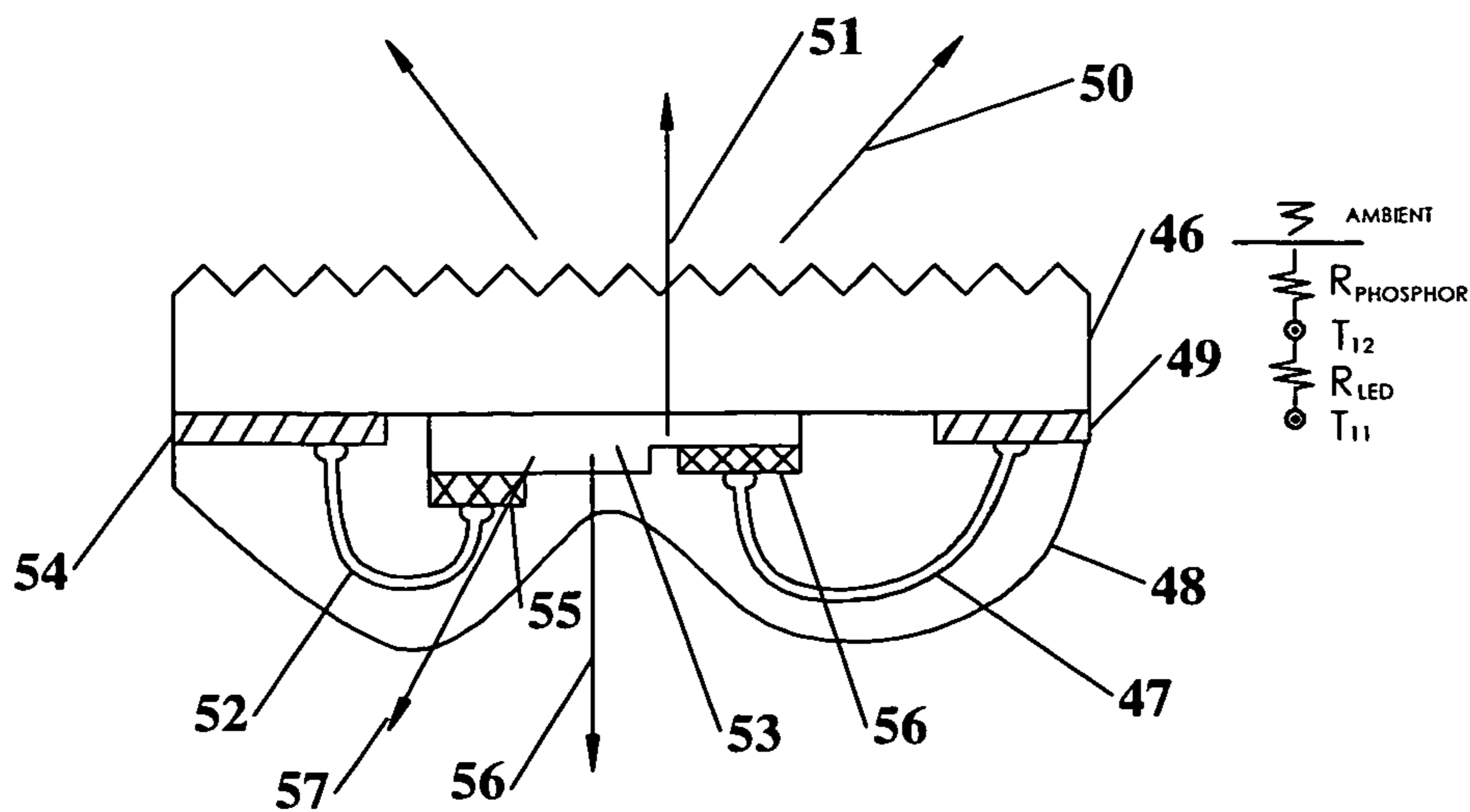
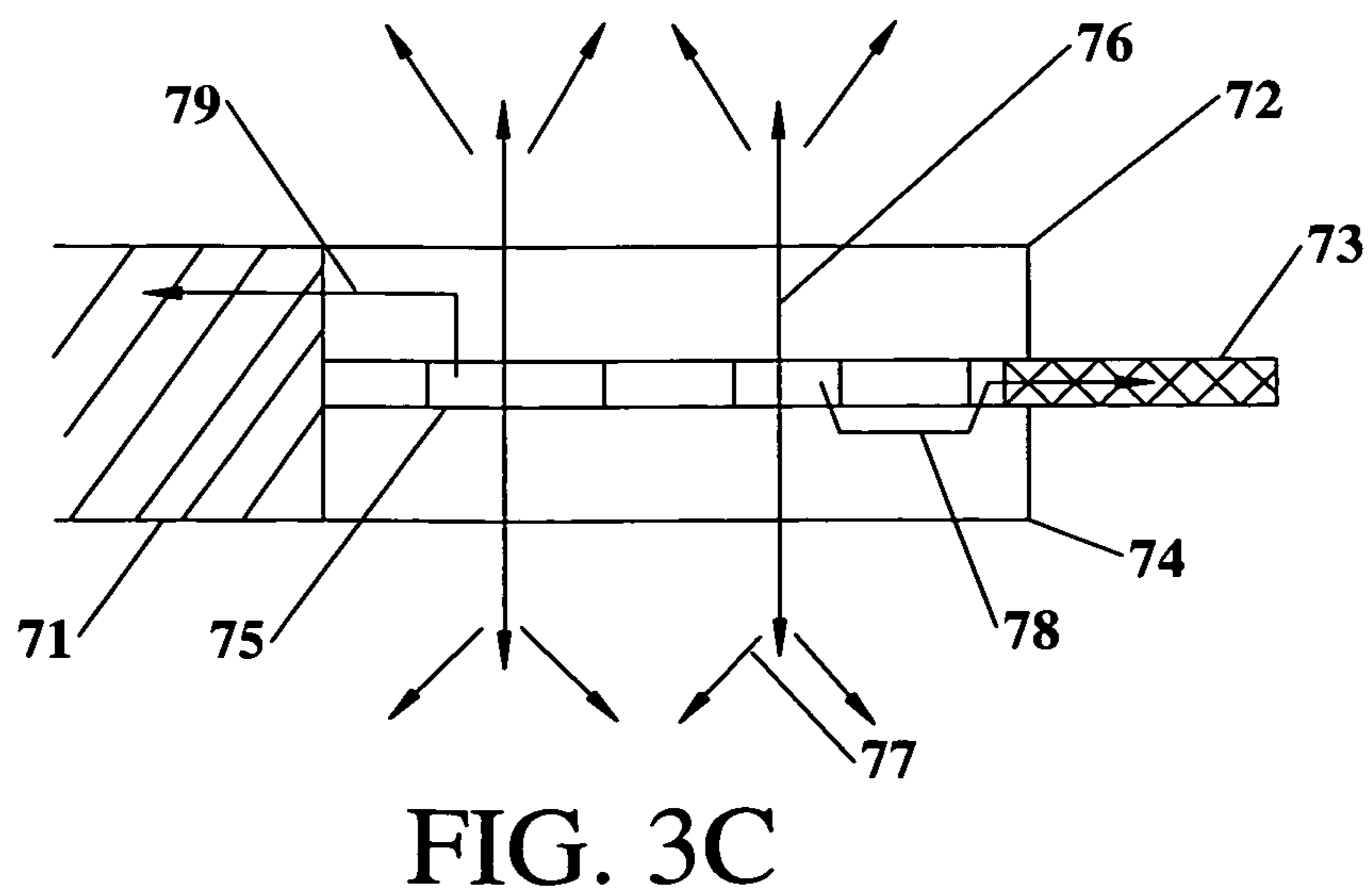
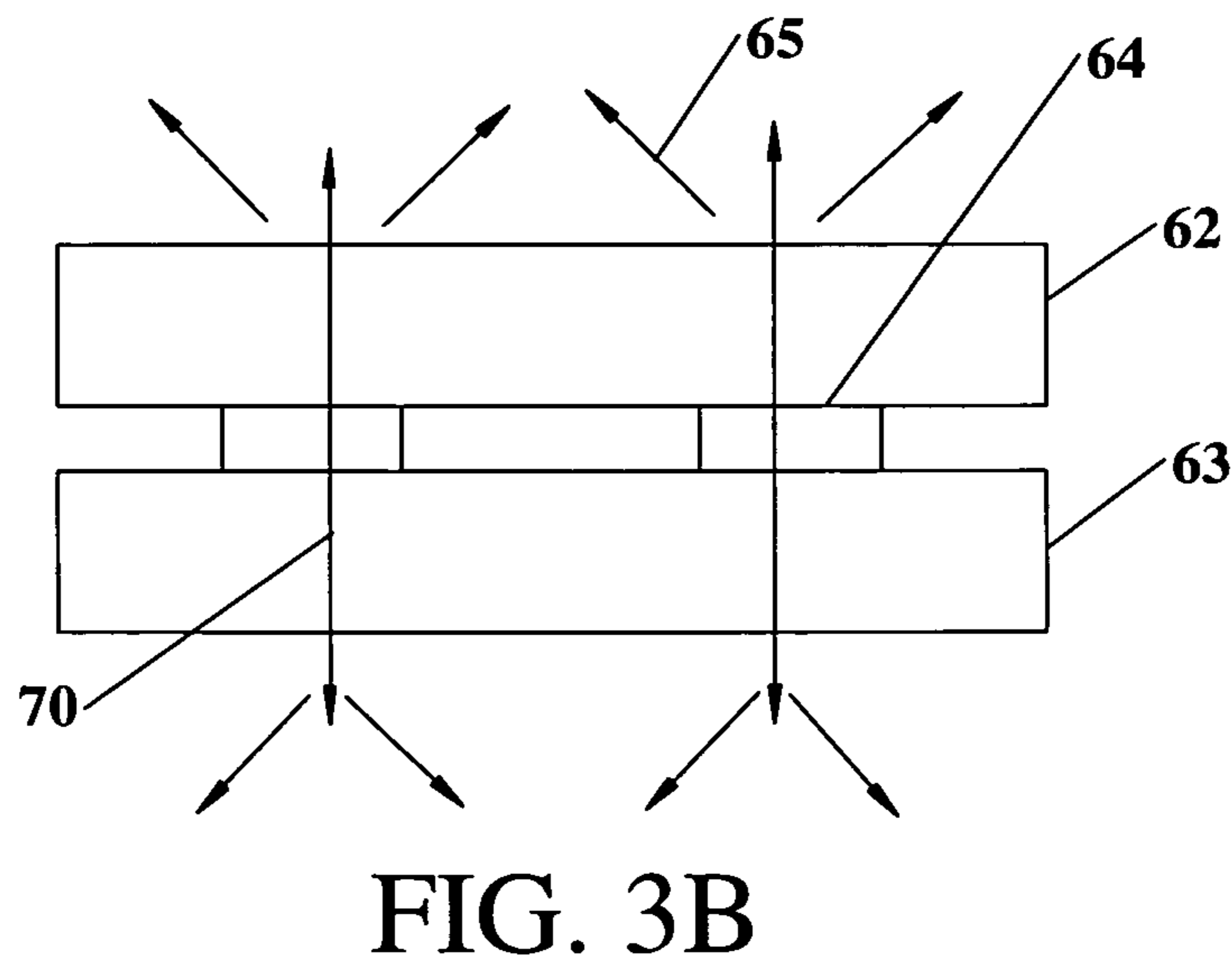
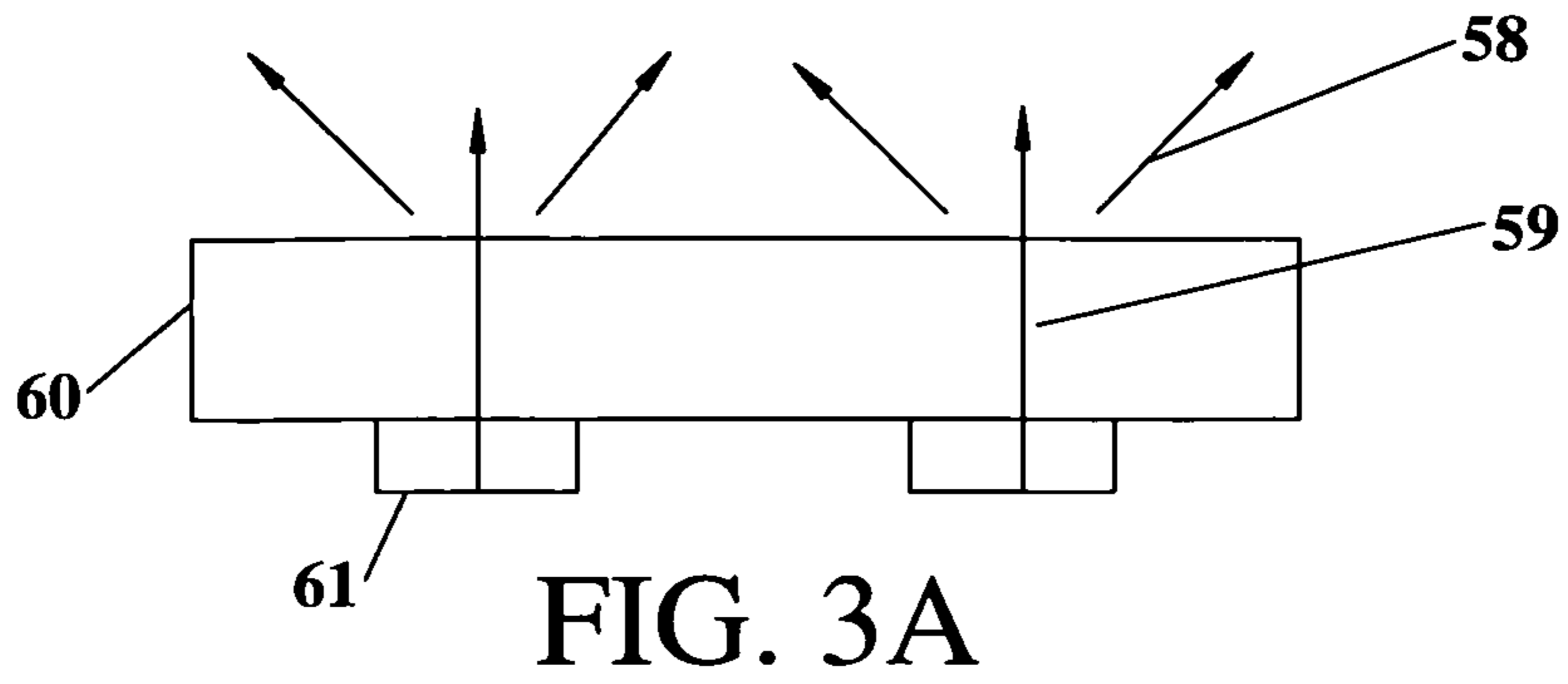

FIG. 2C



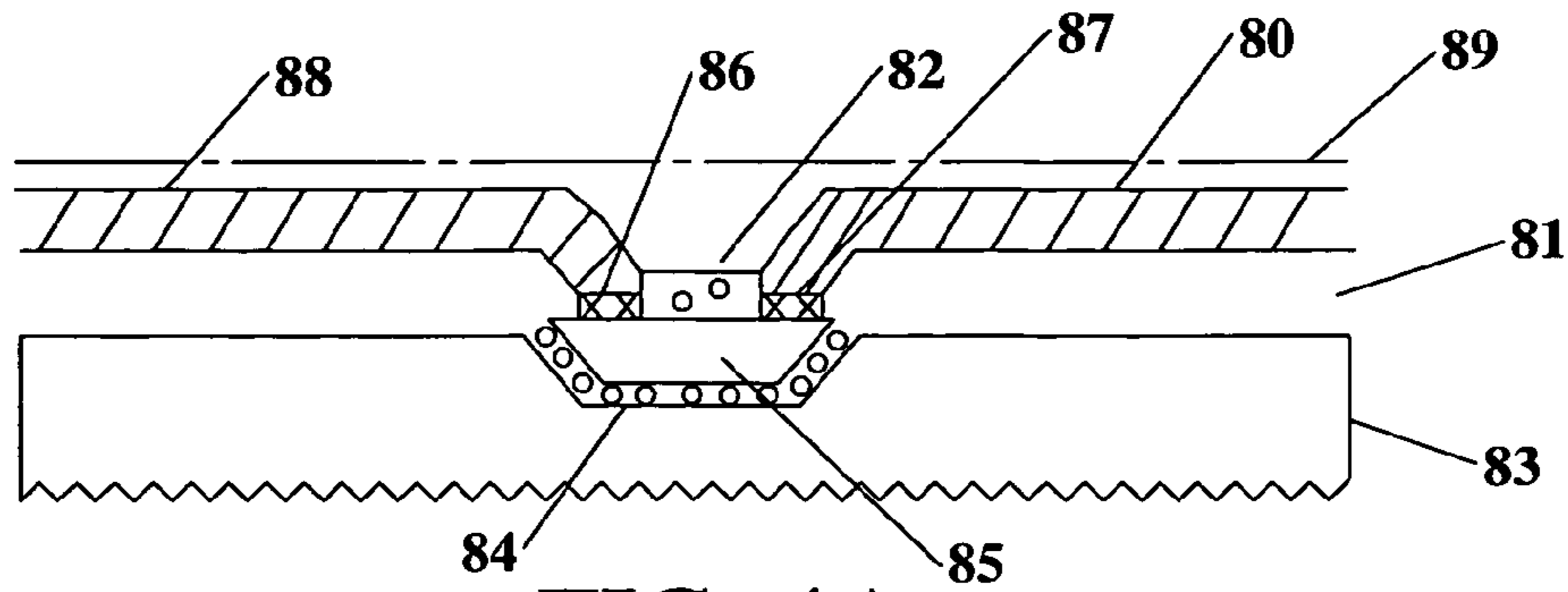

FIG. 4A

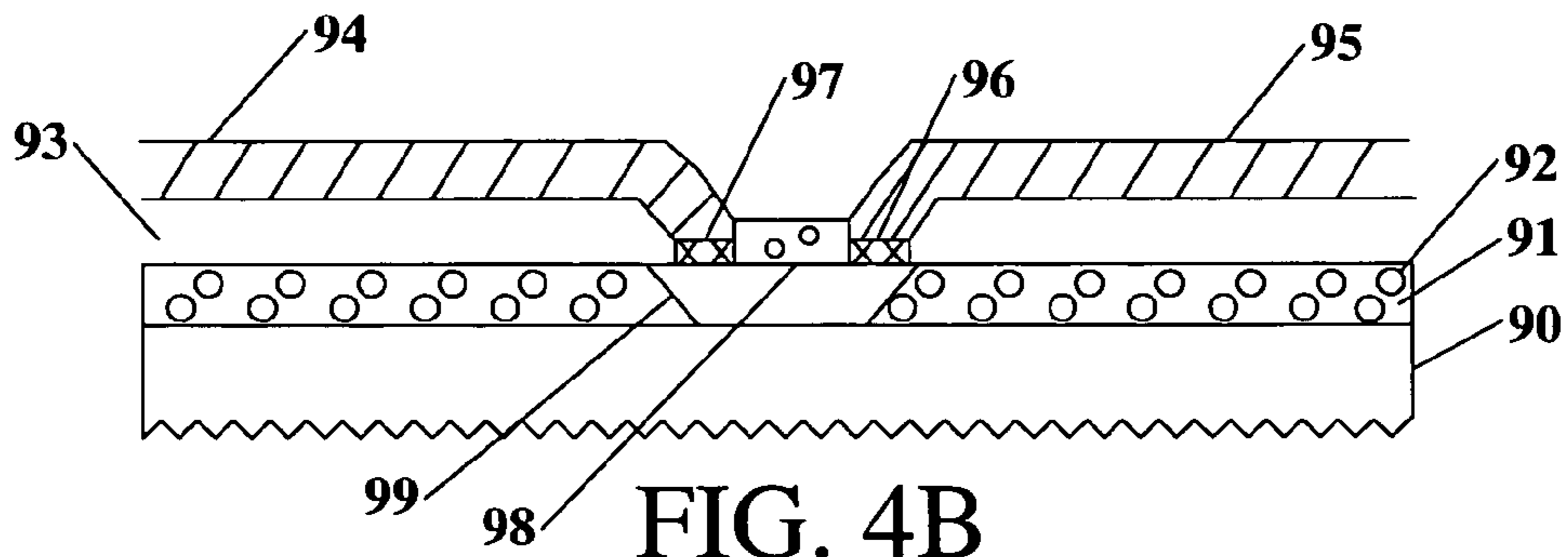

FIG. 4B

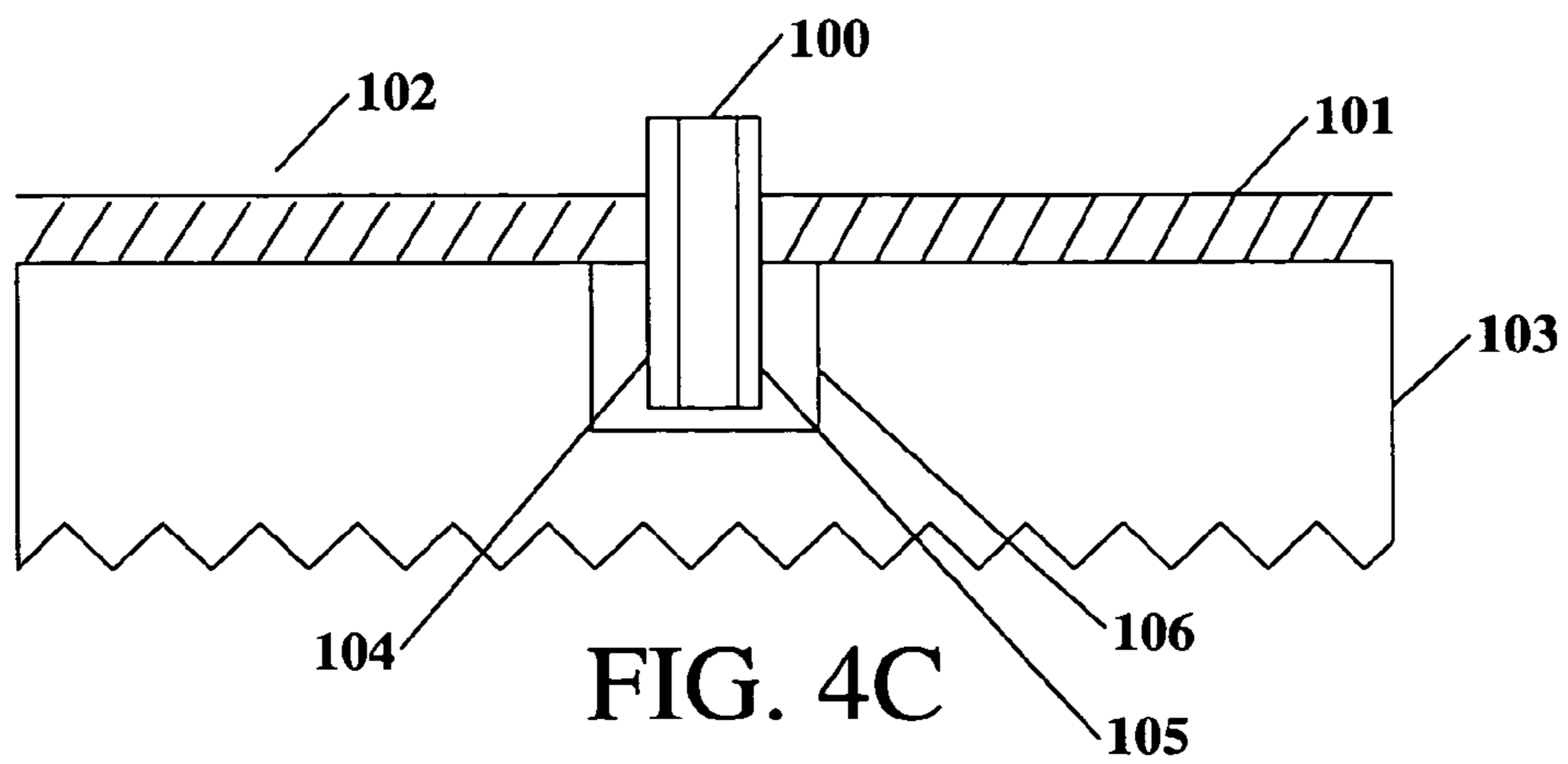

FIG. 4C

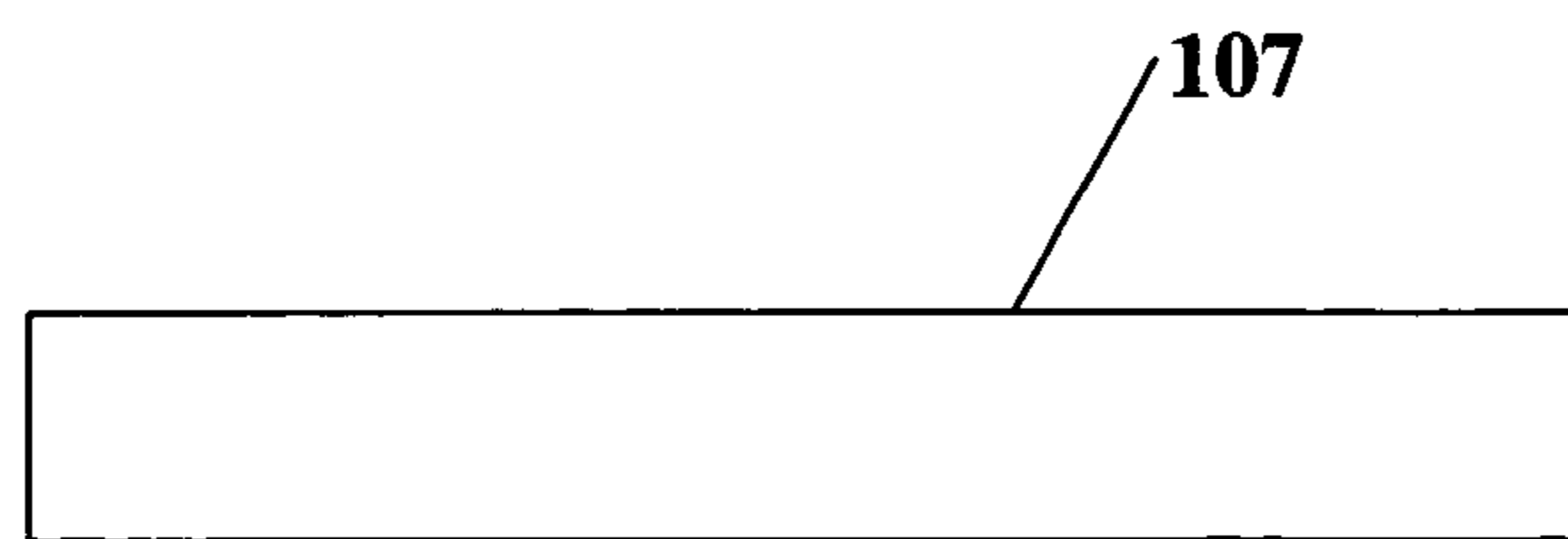

FIG. 5A



FIG. 5B

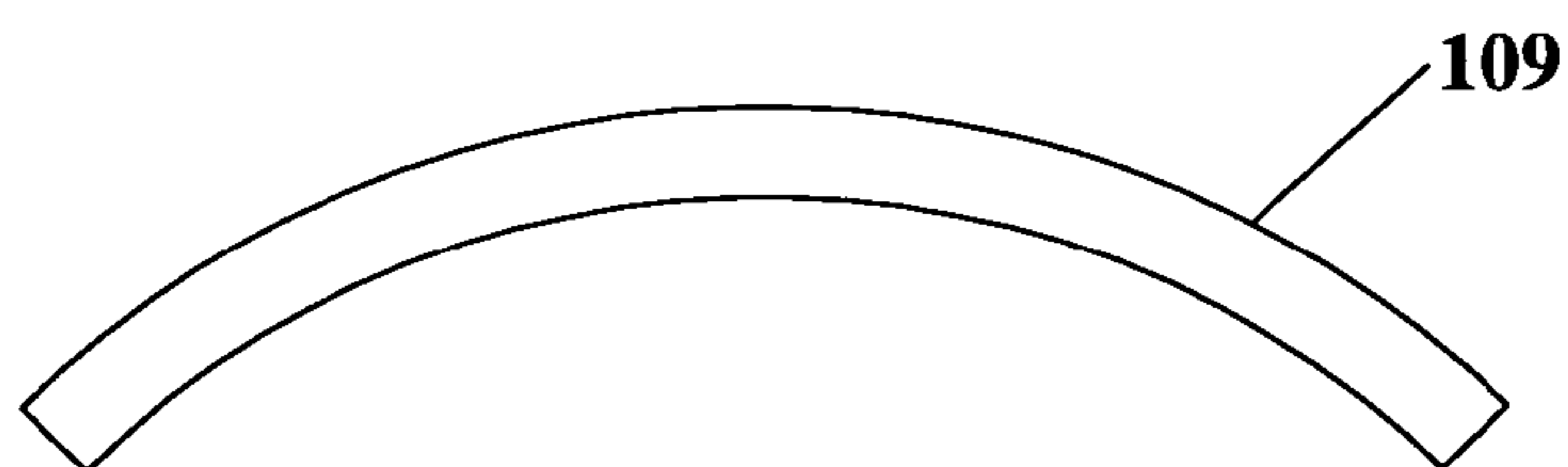

FIG. 5C

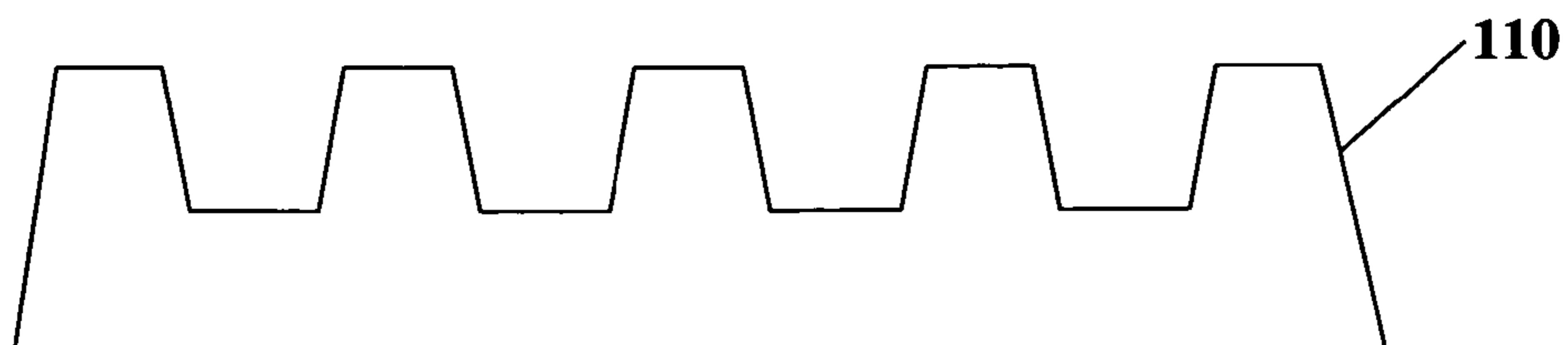

FIG. 5D

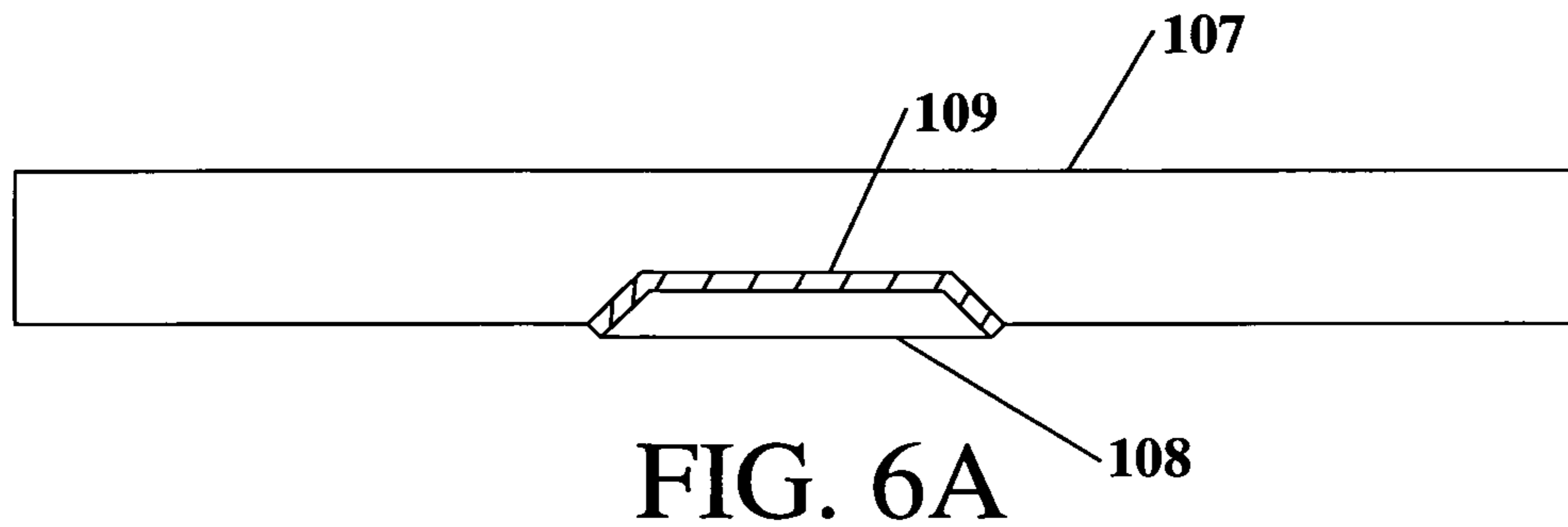

FIG. 6A

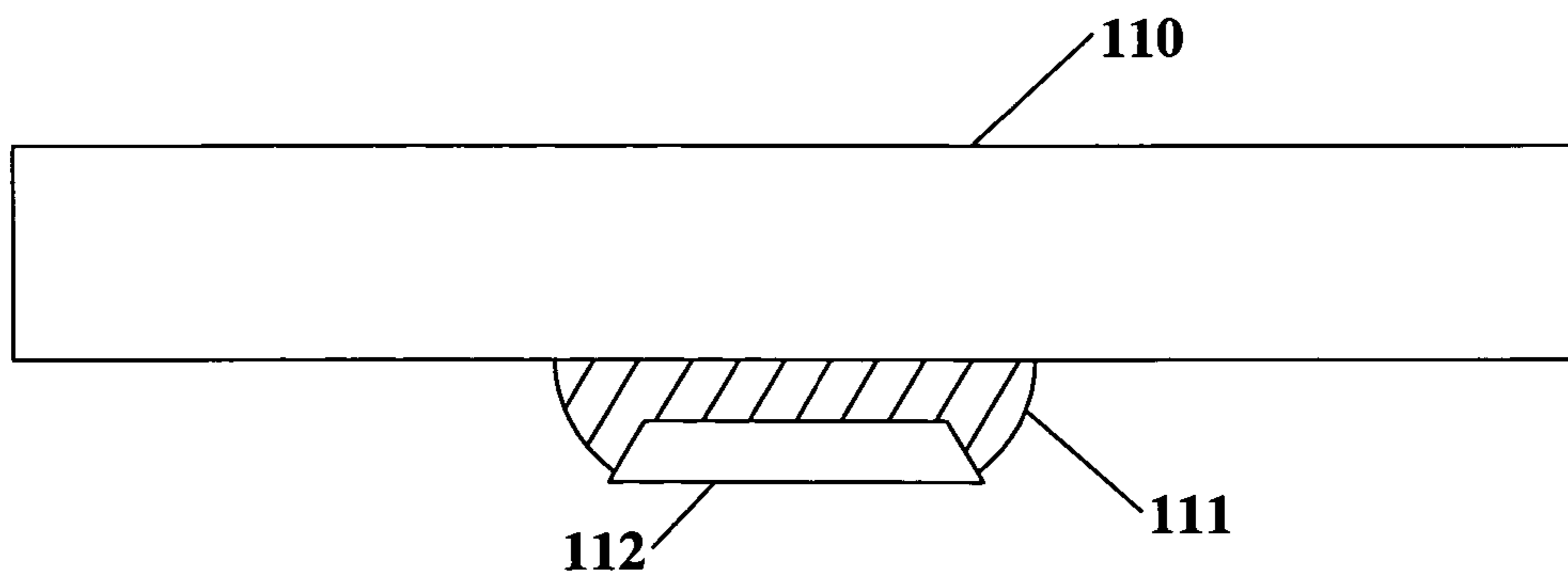

FIG. 6B

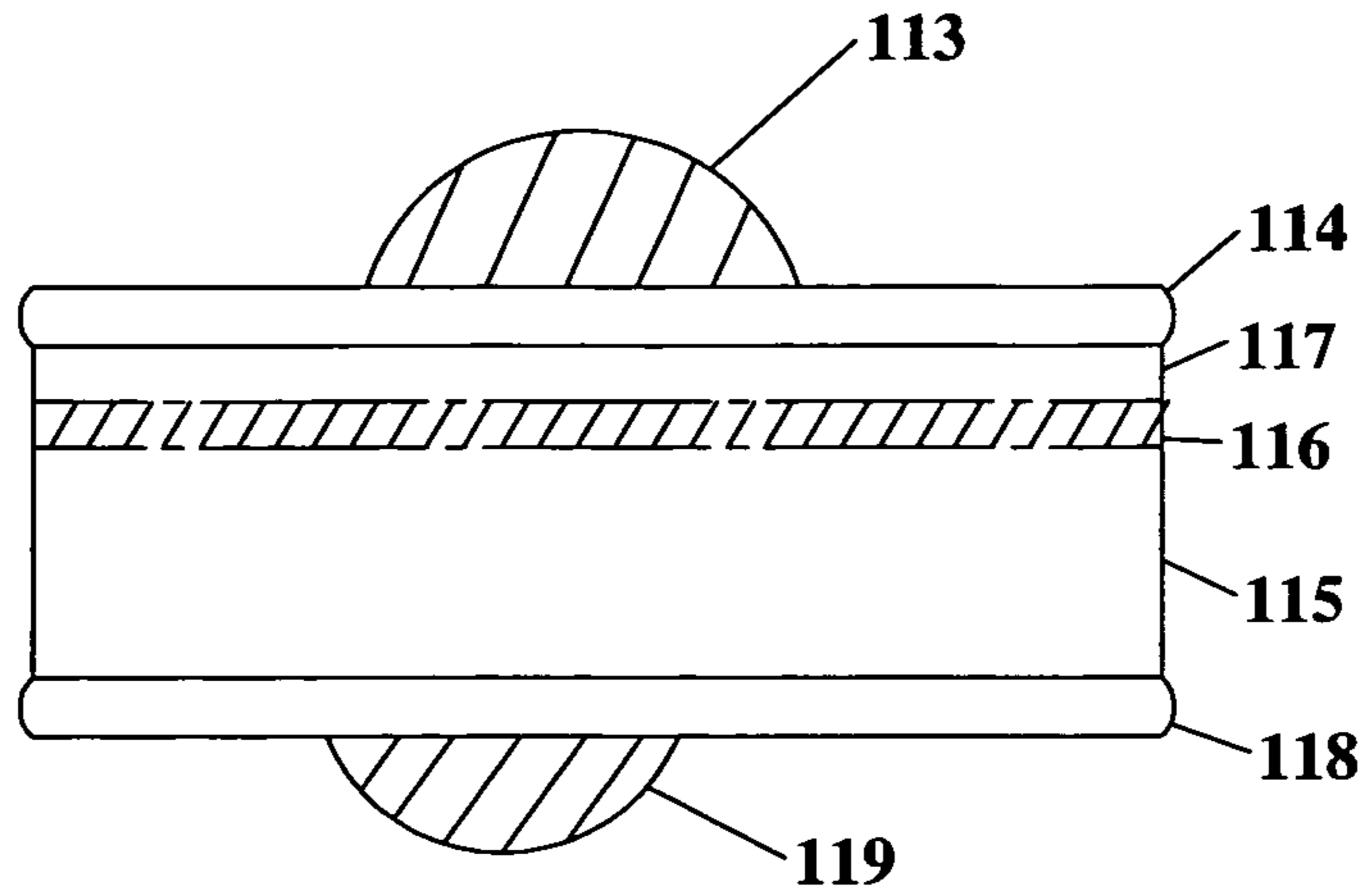

FIG. 7A

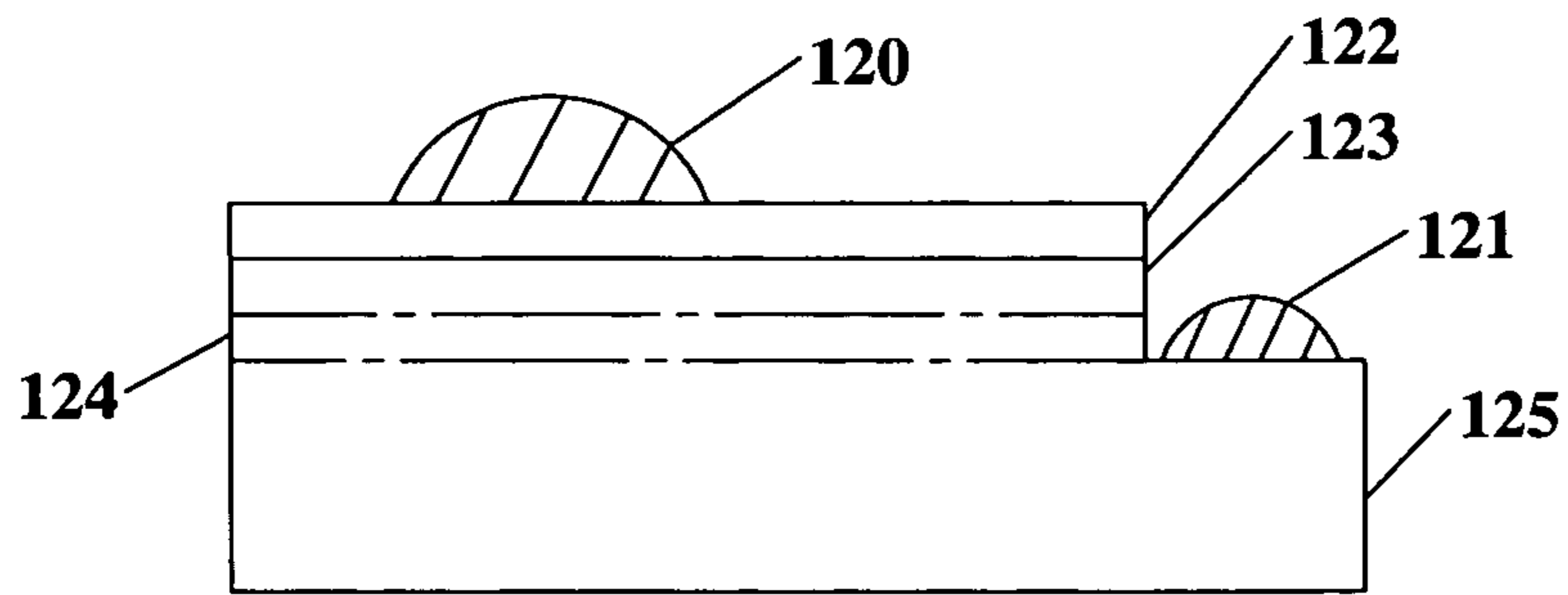

FIG. 7B

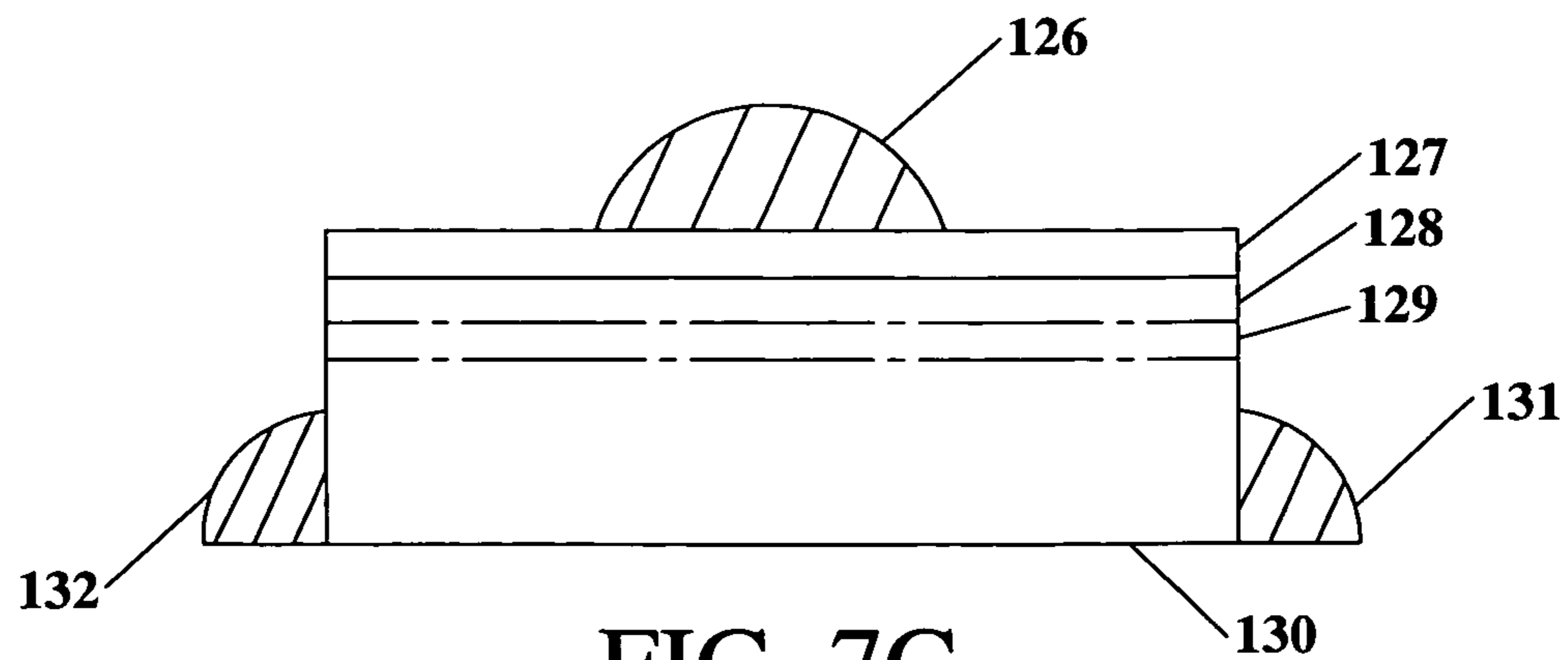

FIG. 7C

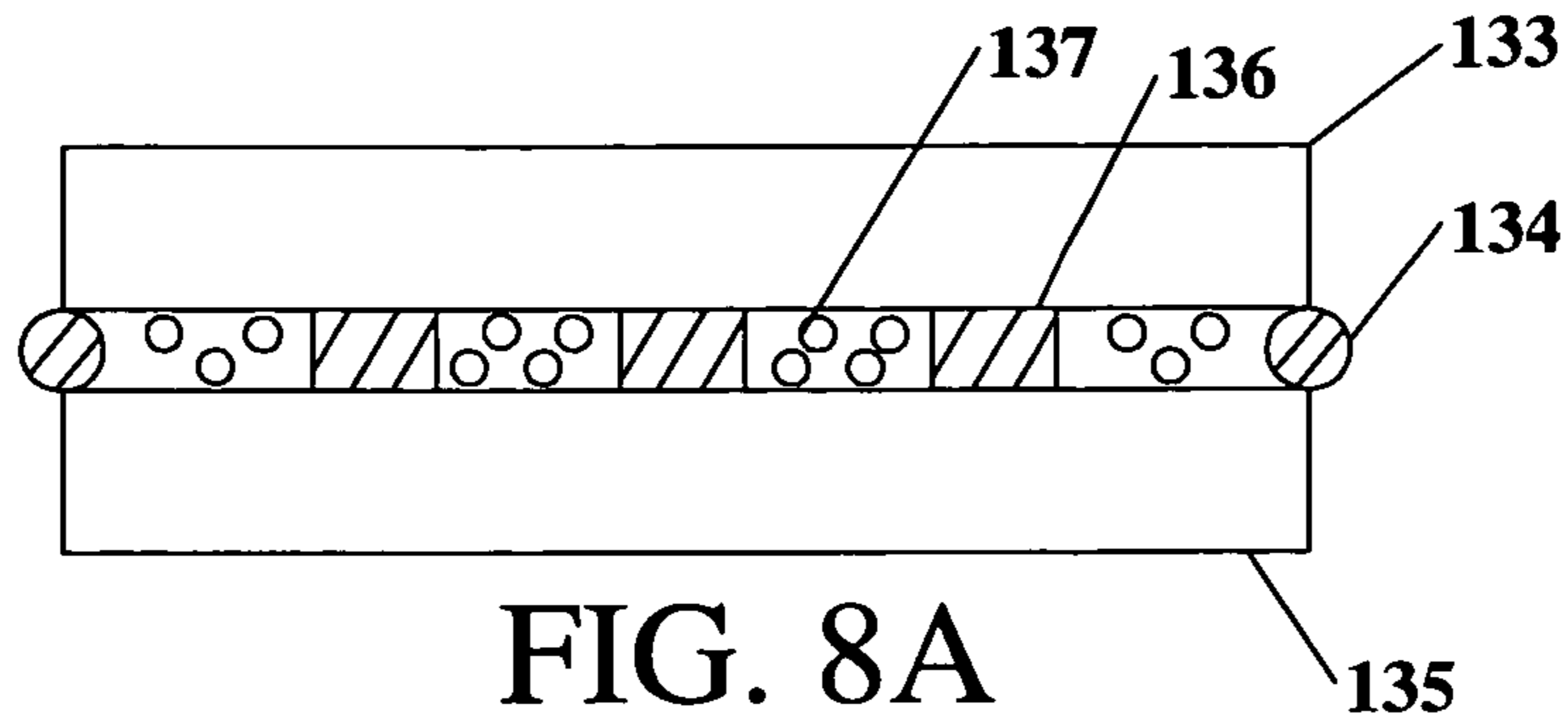

FIG. 8A

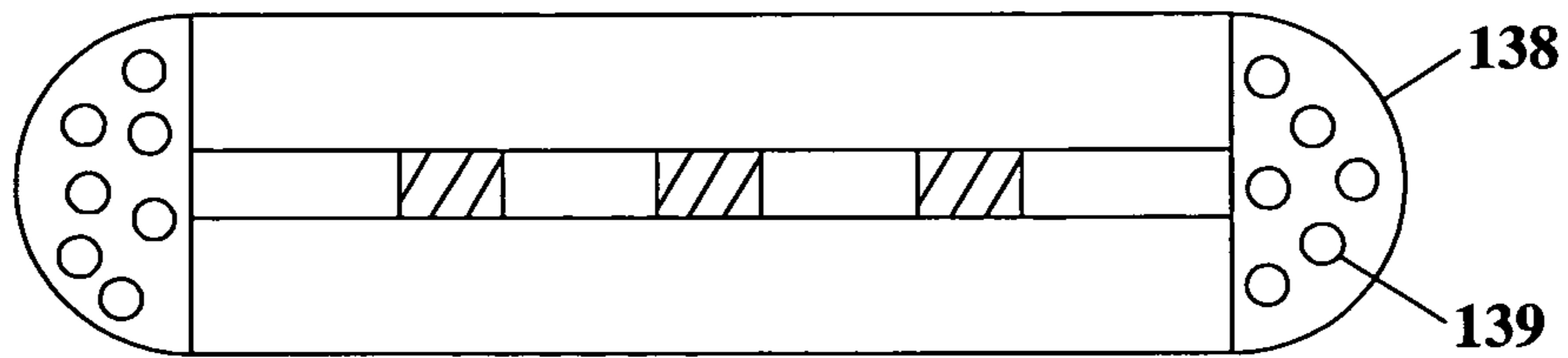

FIG. 8B

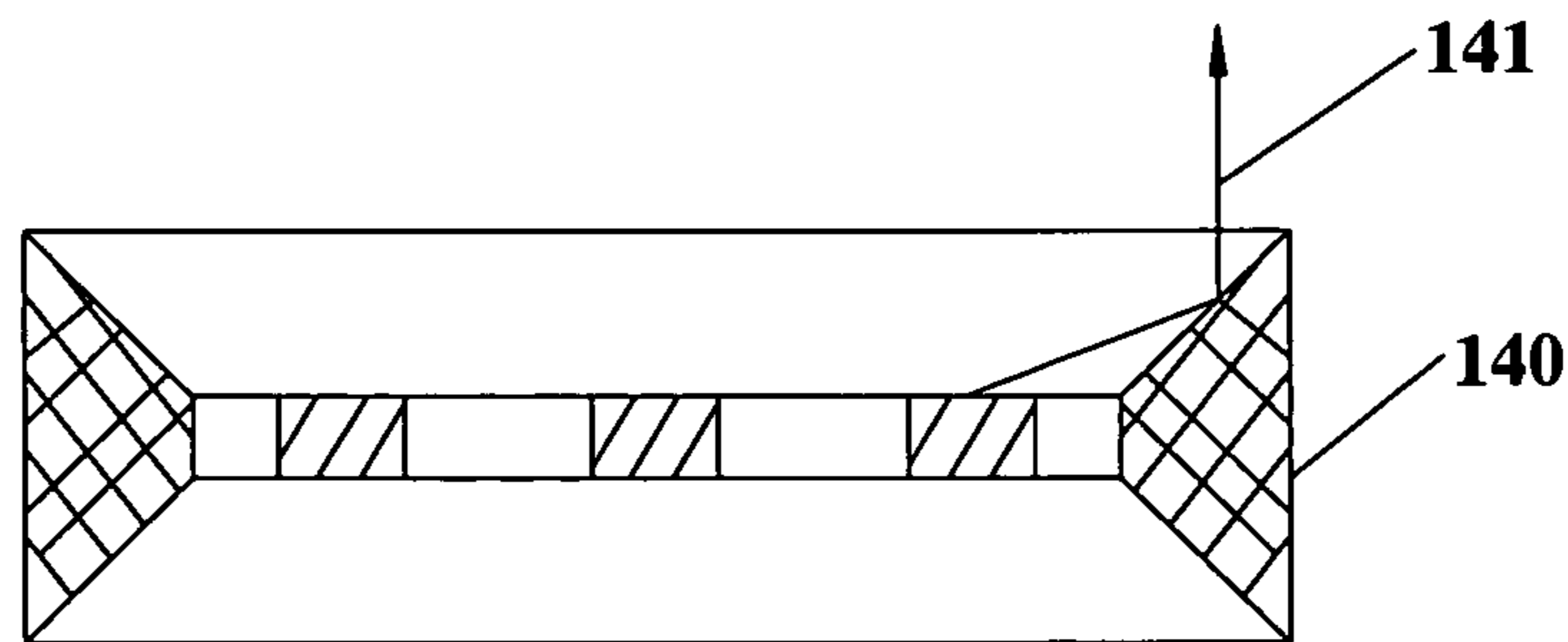

FIG. 8C

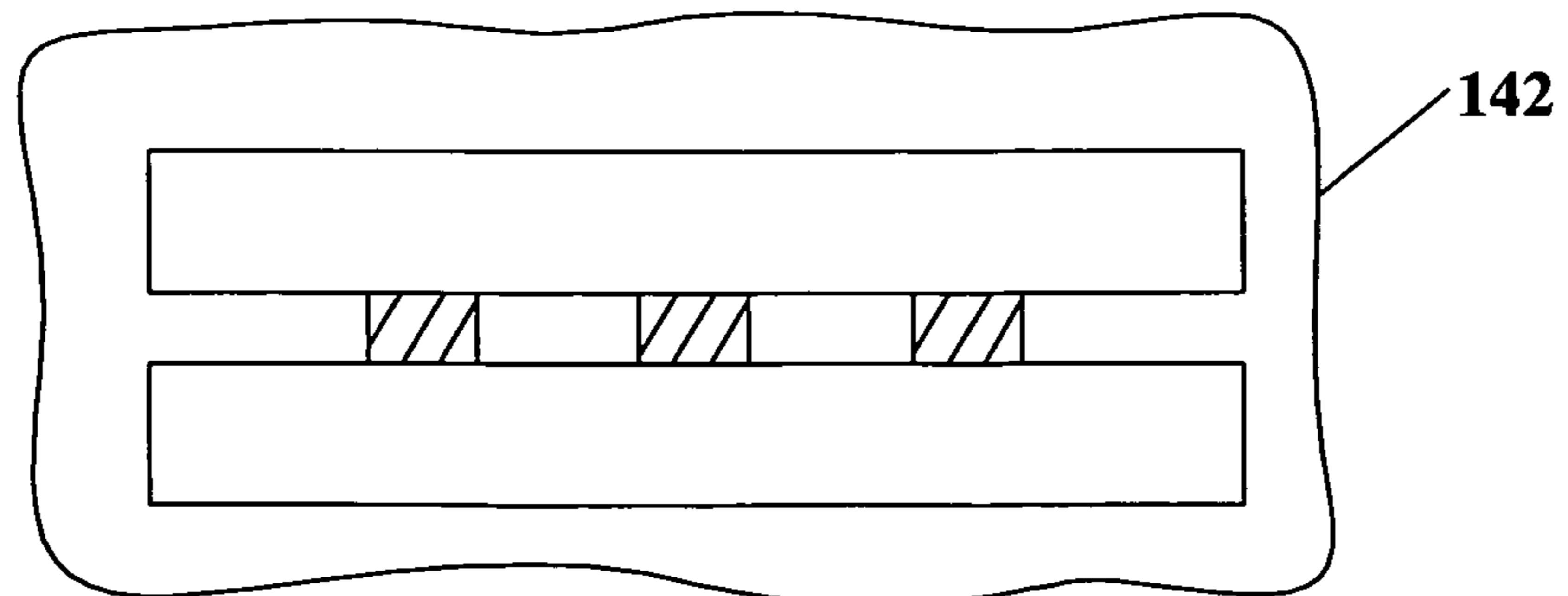

FIG. 8D

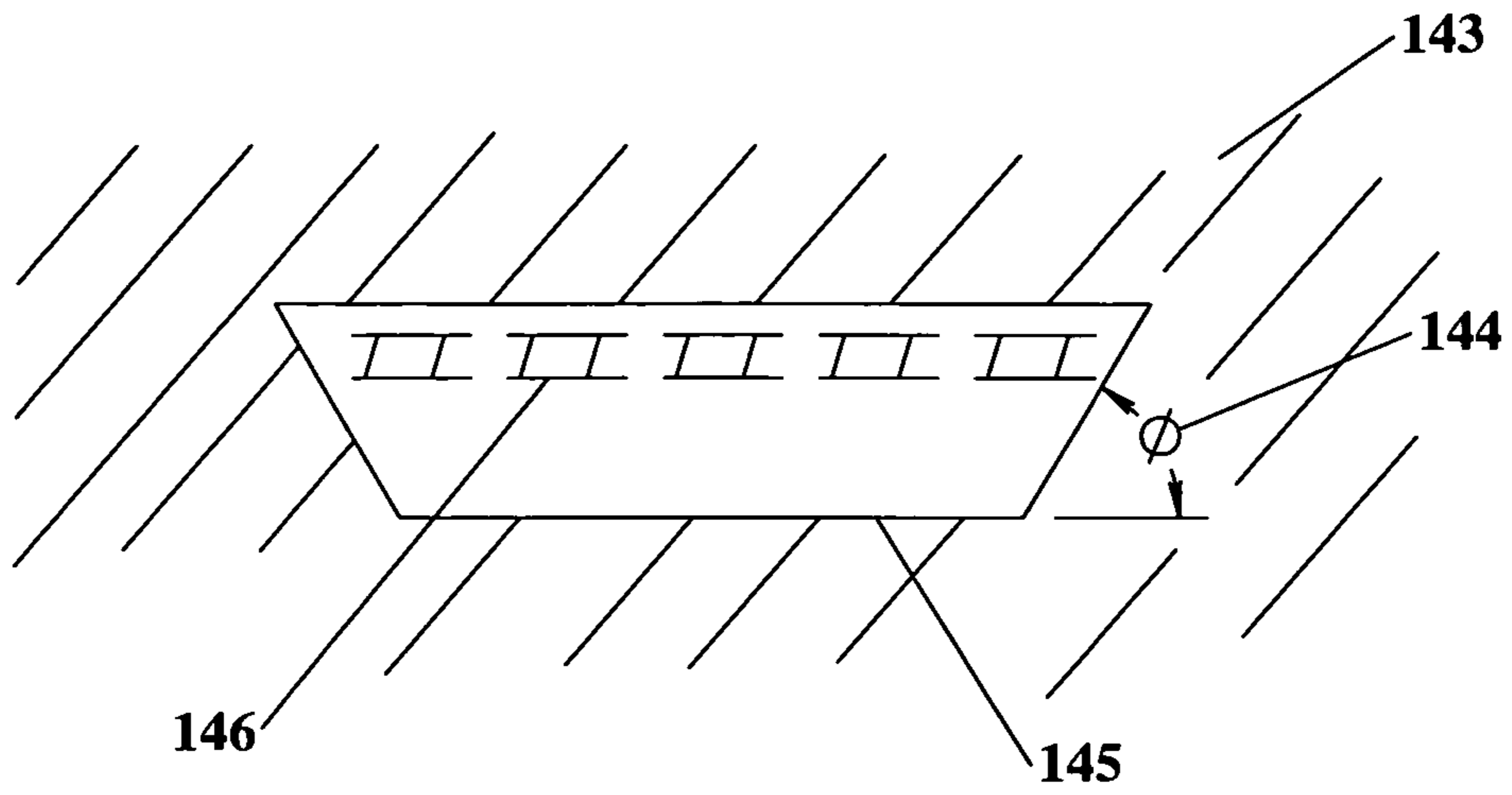

FIG. 9A

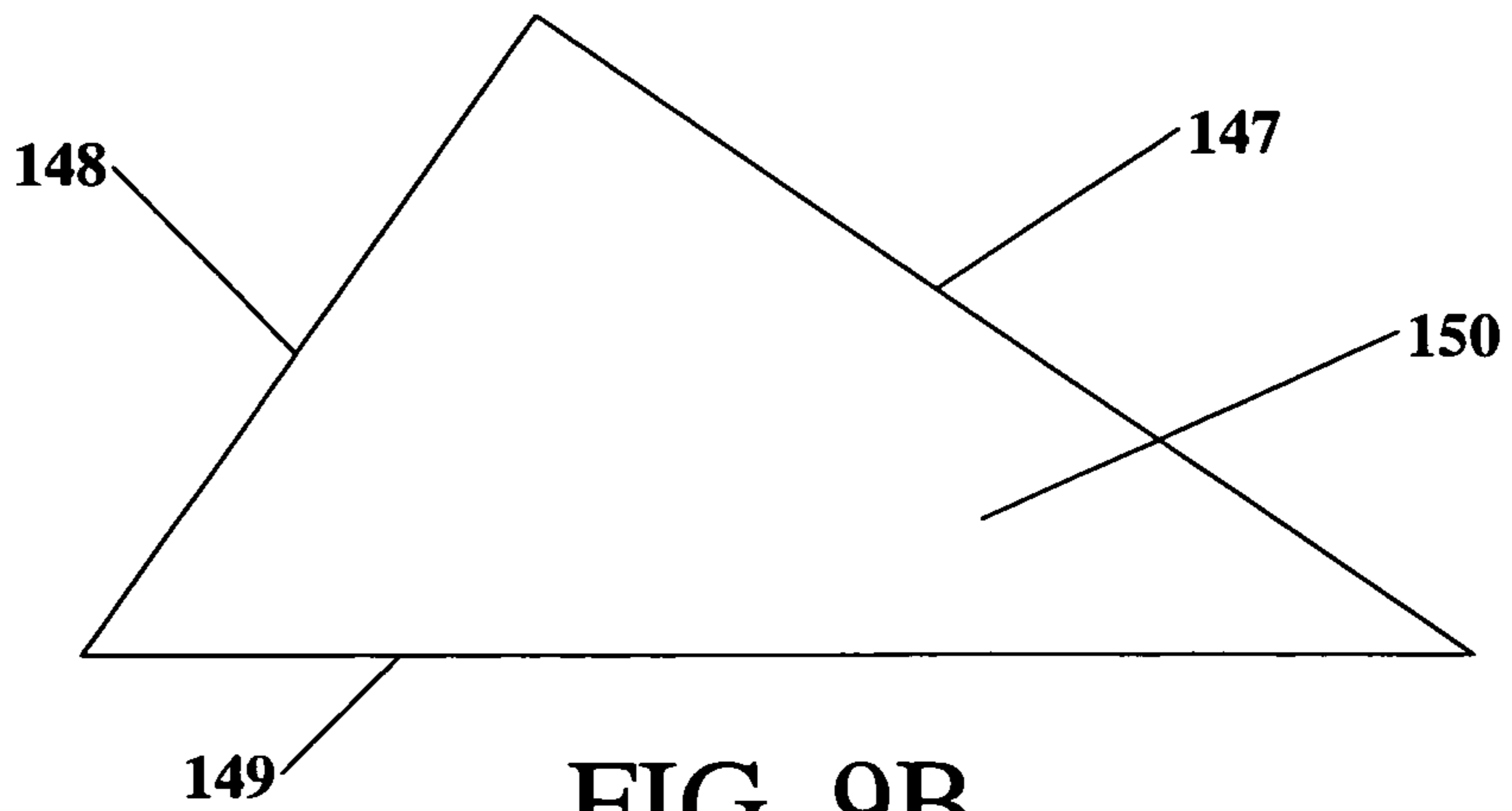

FIG. 9B

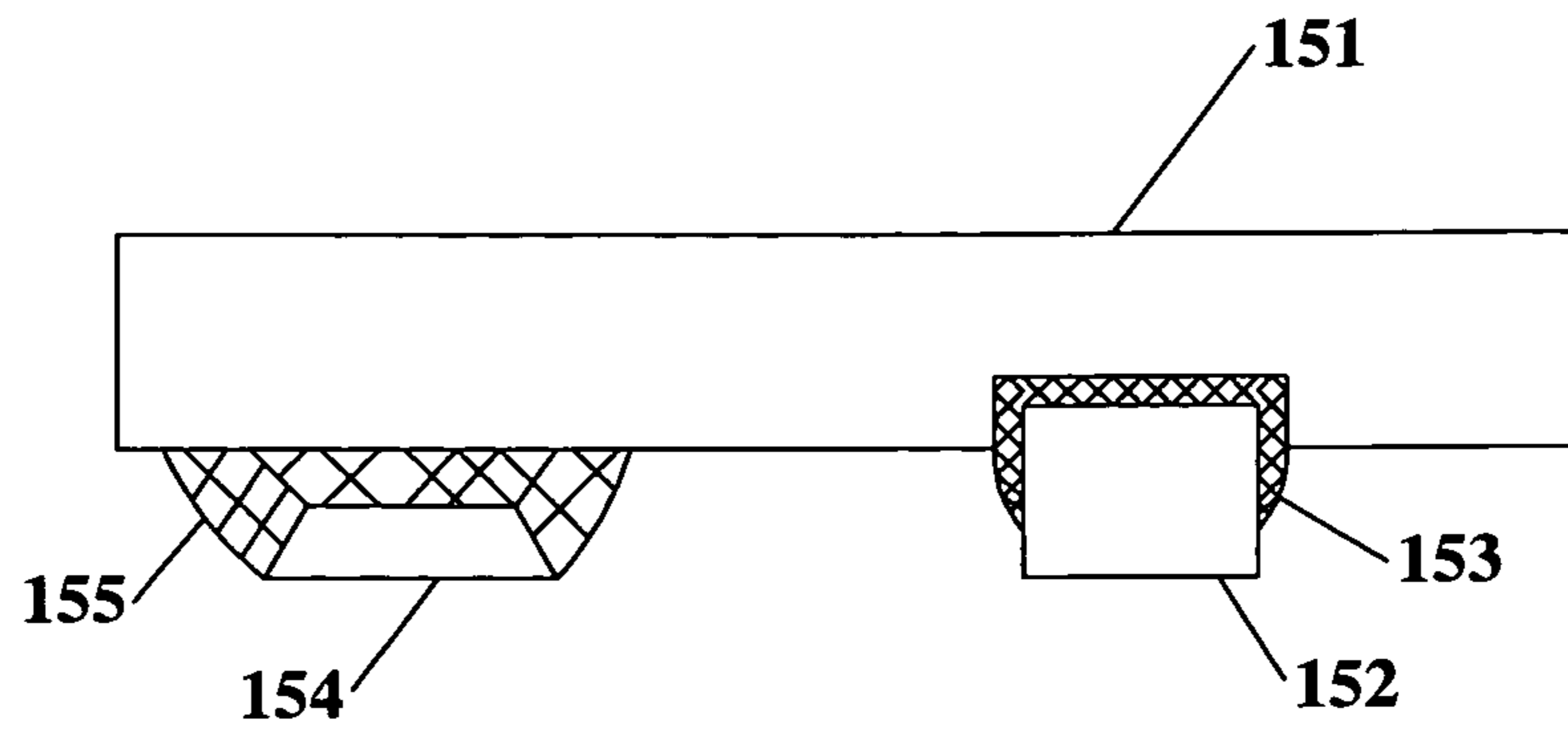

FIG. 10A

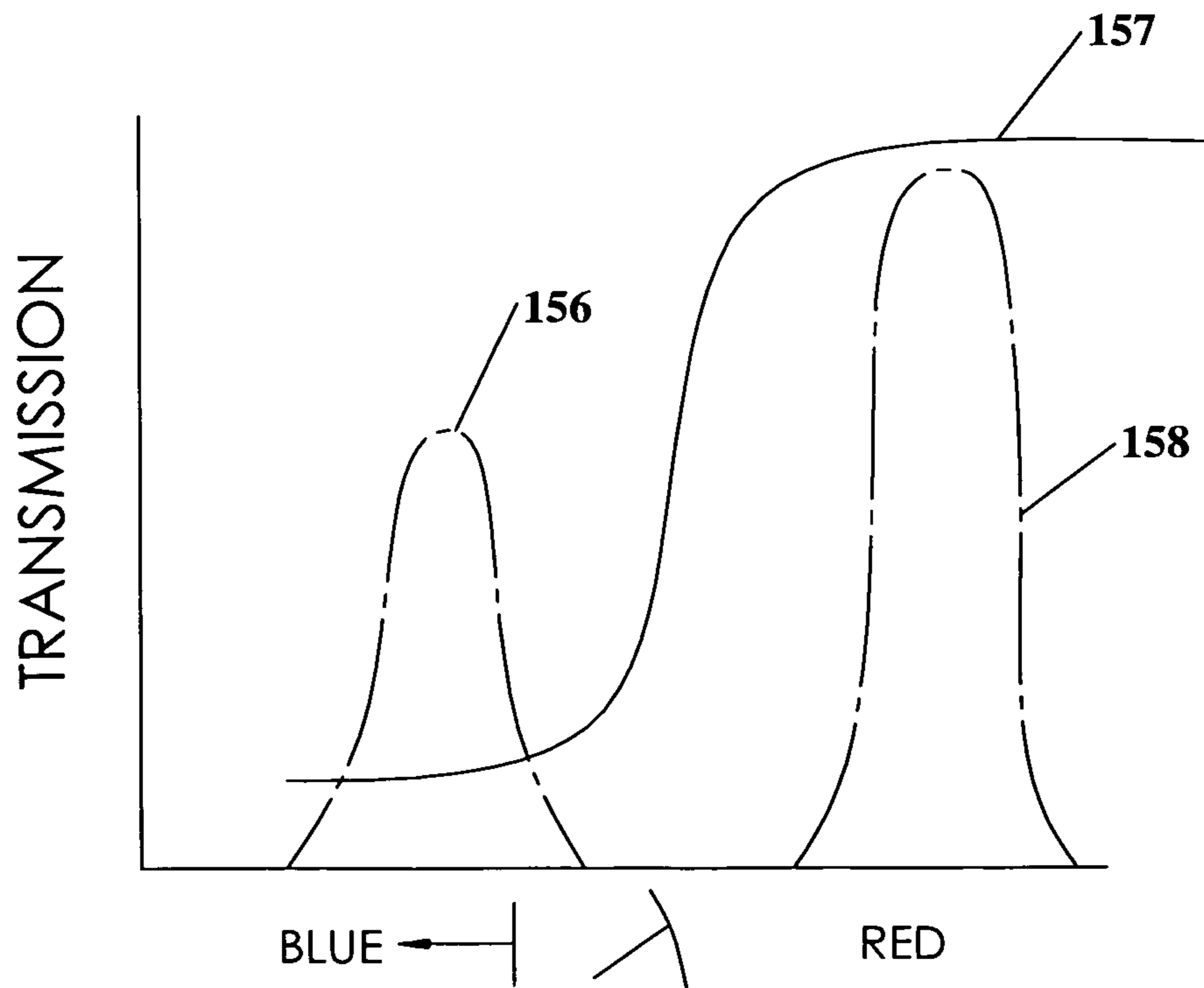

FIG. 10B

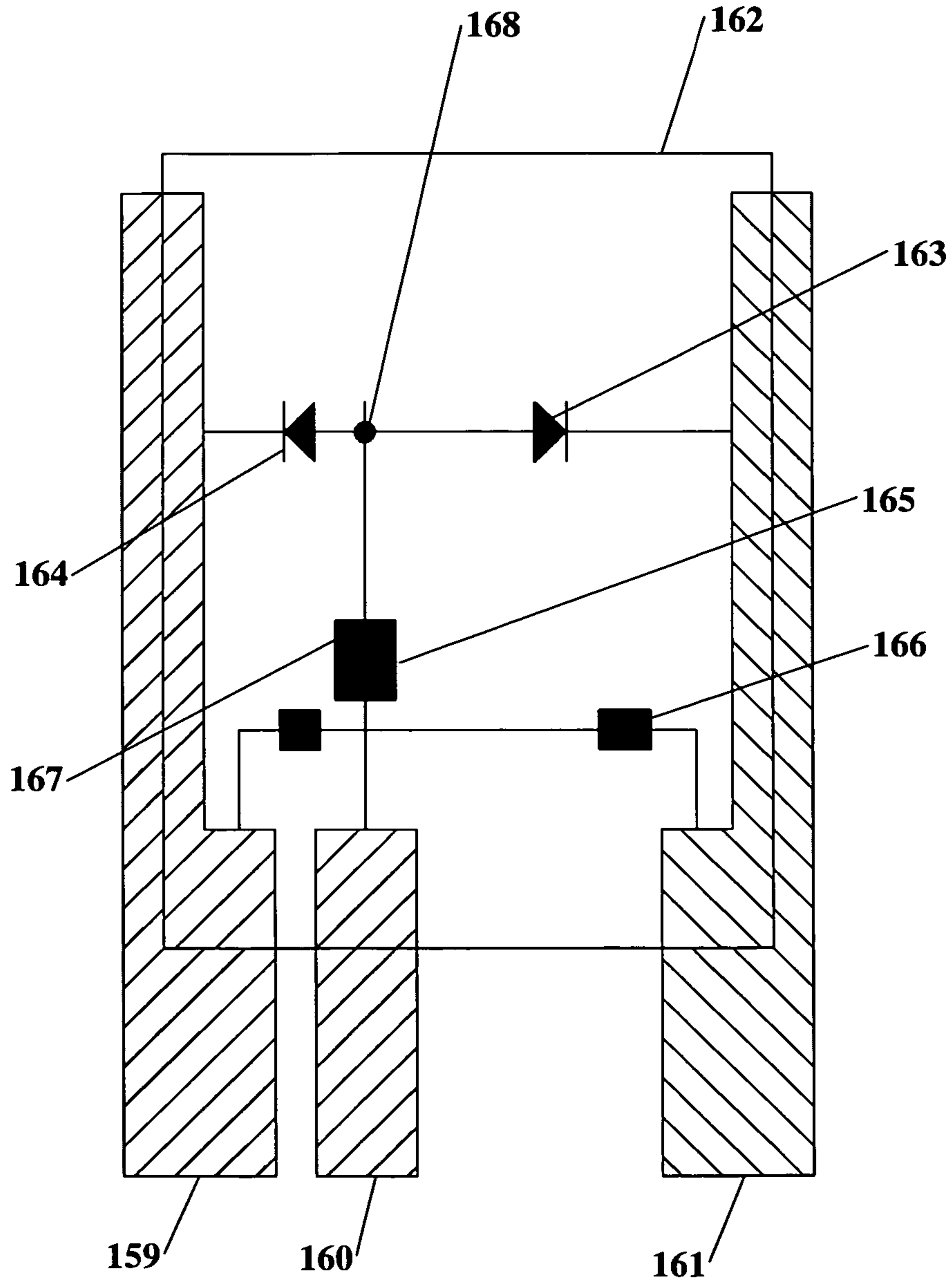

FIG. 11

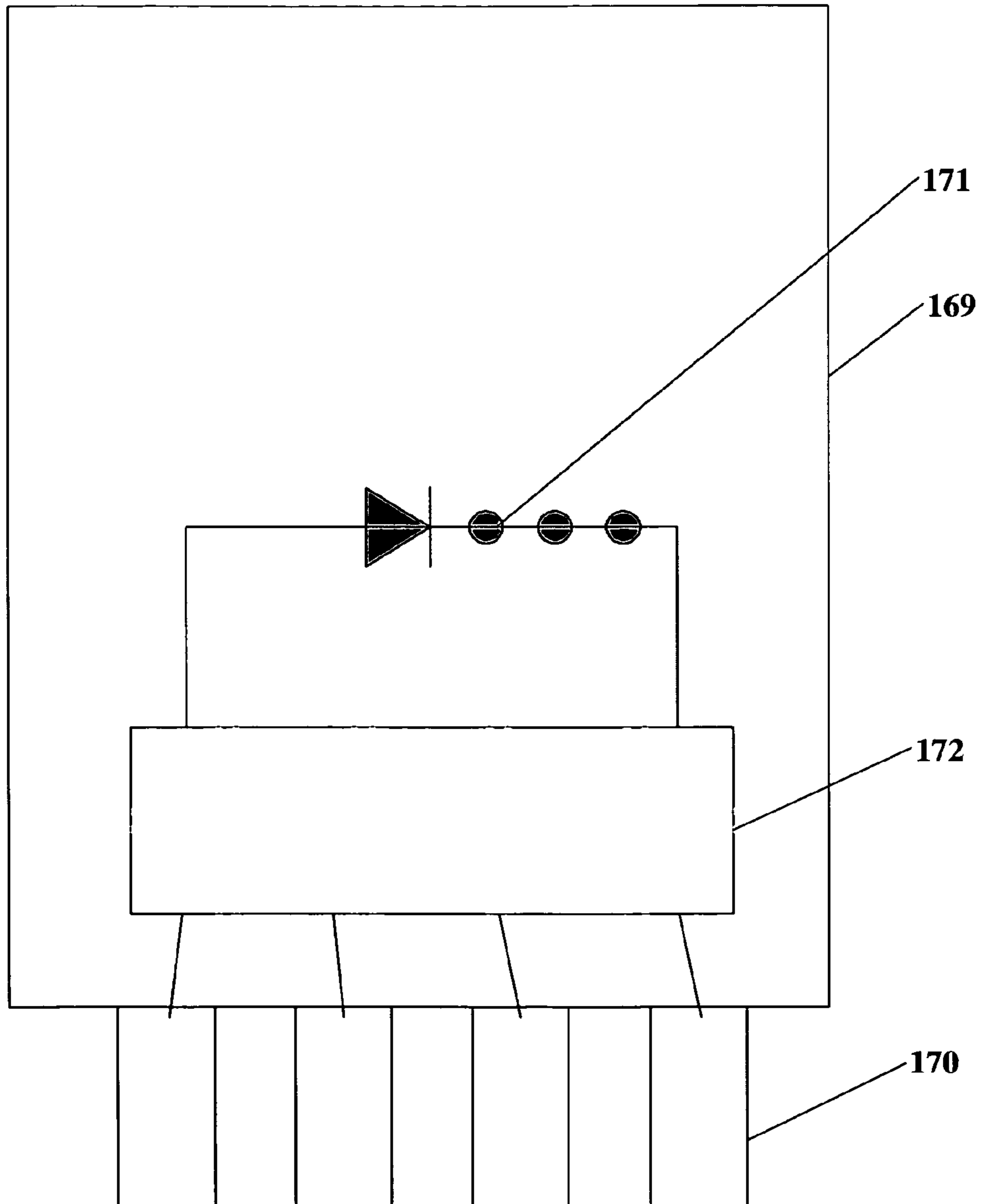

FIG. 12

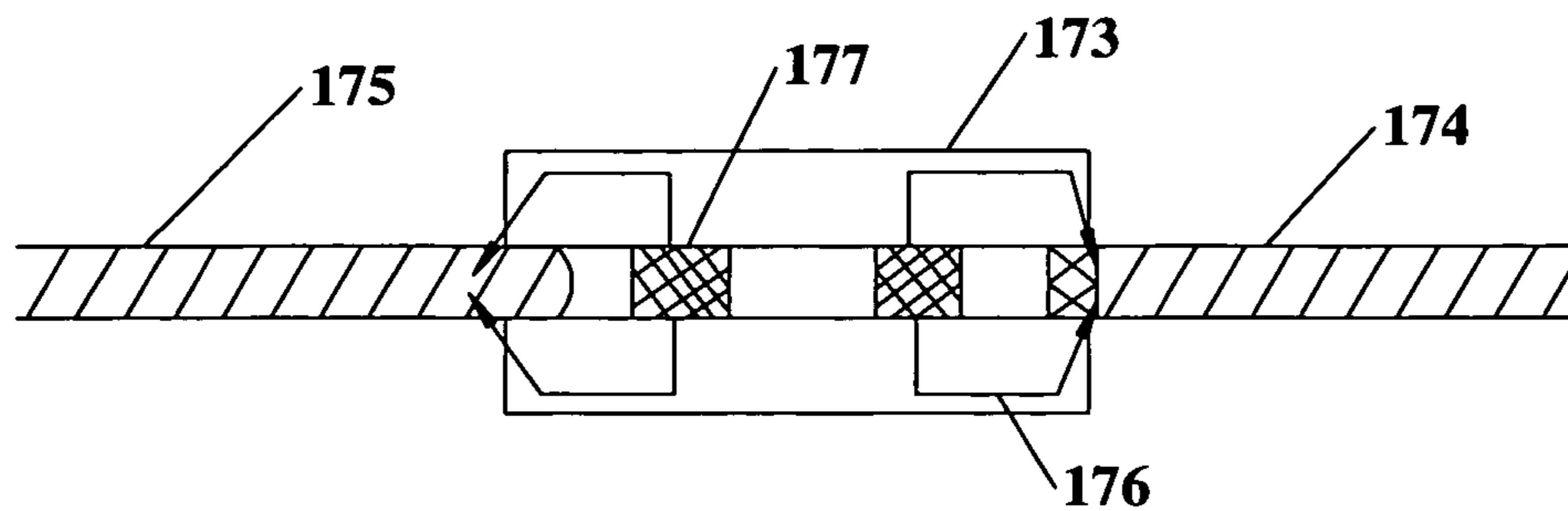

FIG. 13A

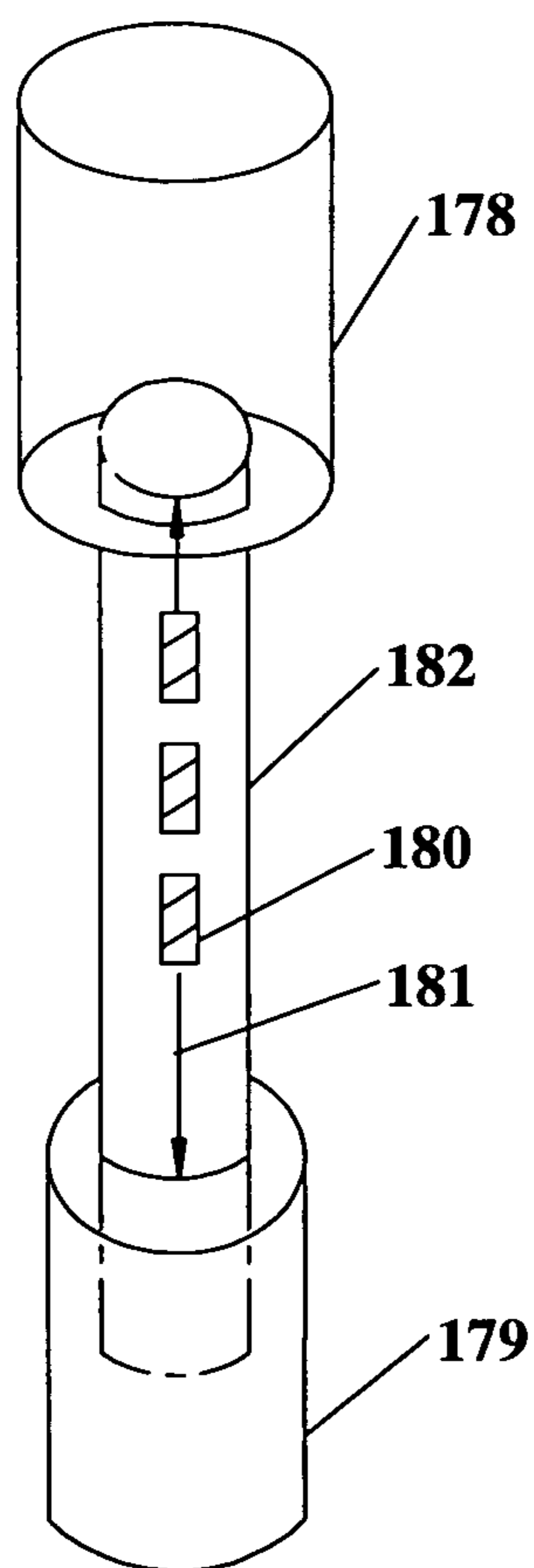

FIG. 13B

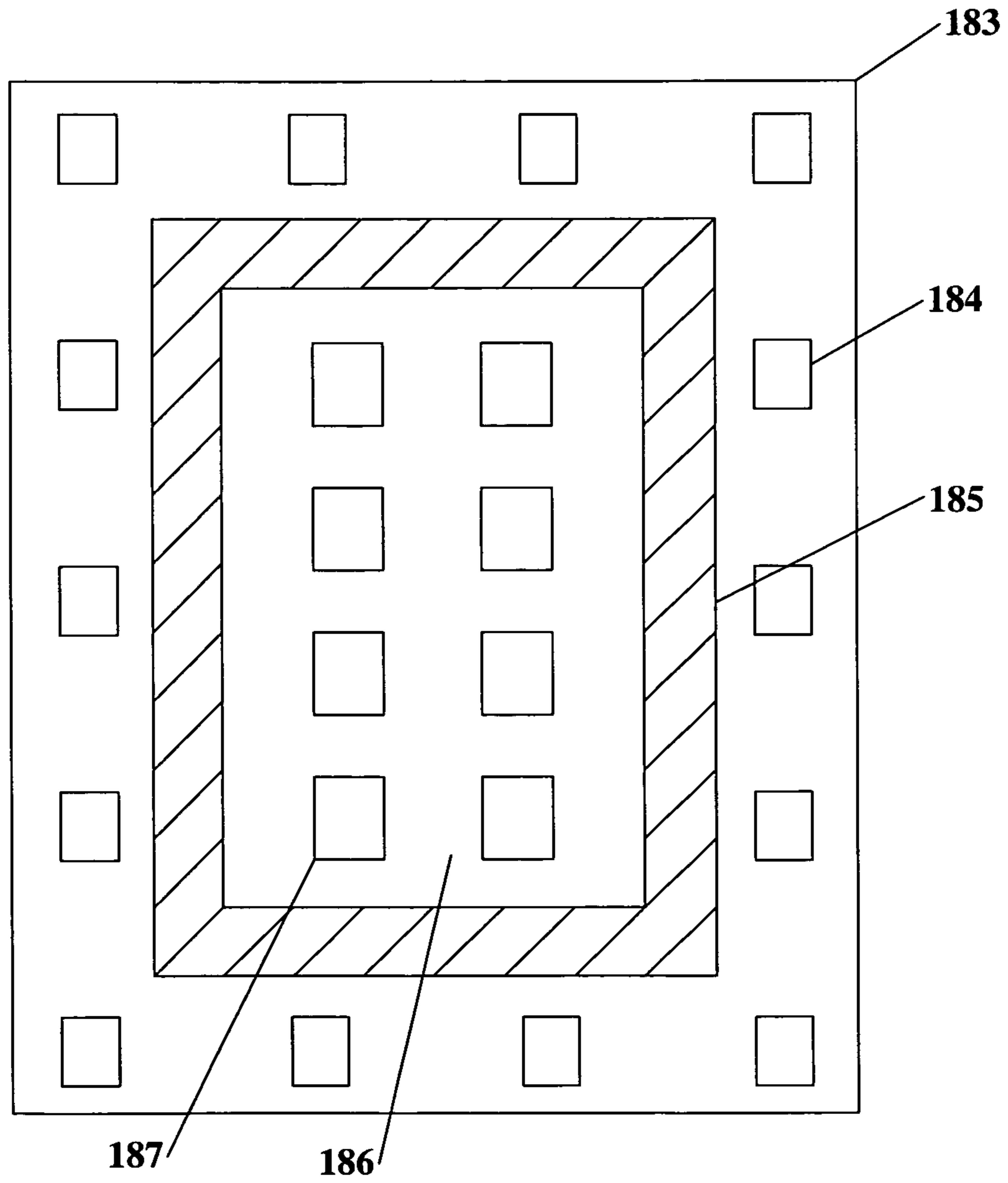

FIG. 14

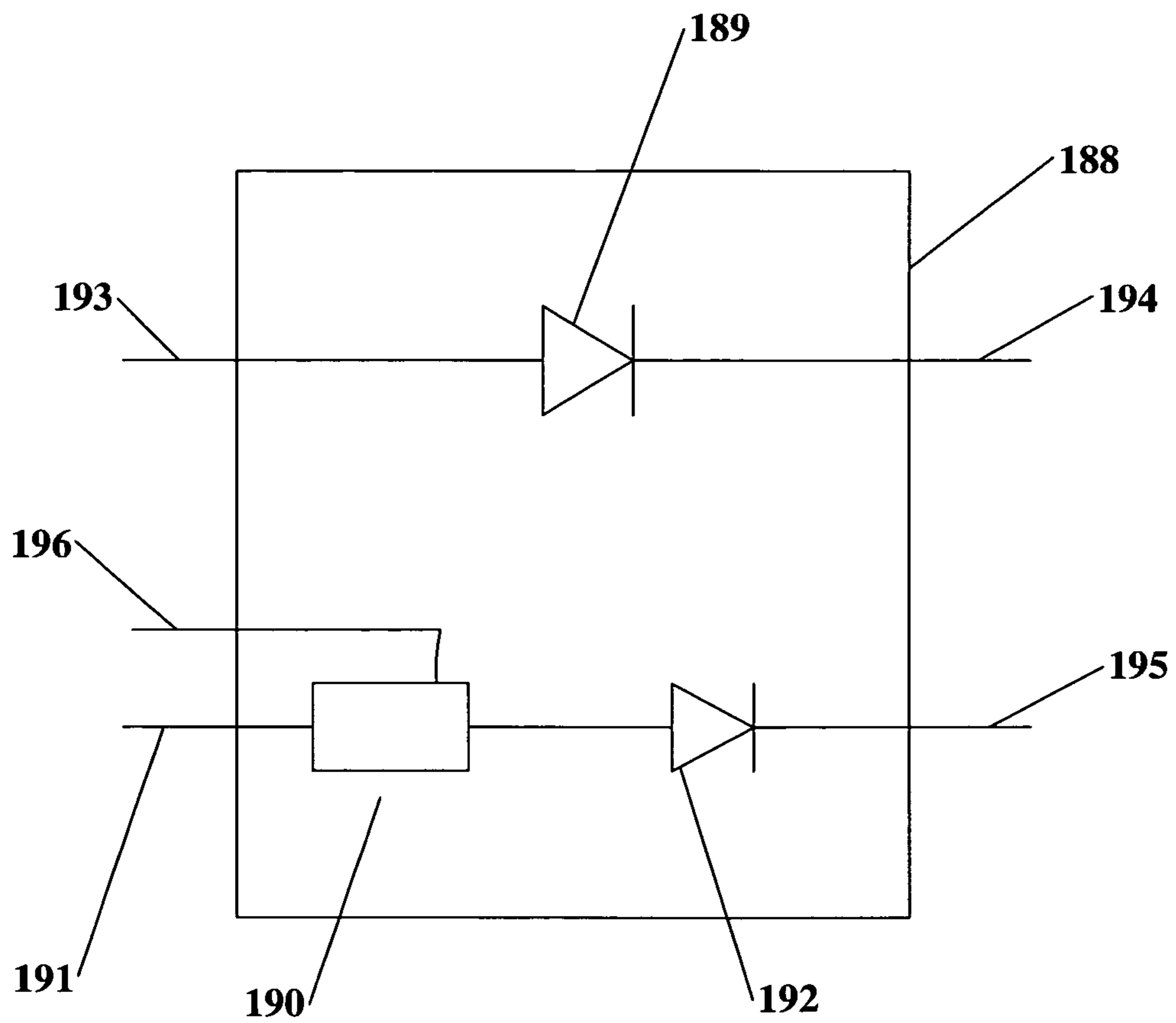

FIG 15

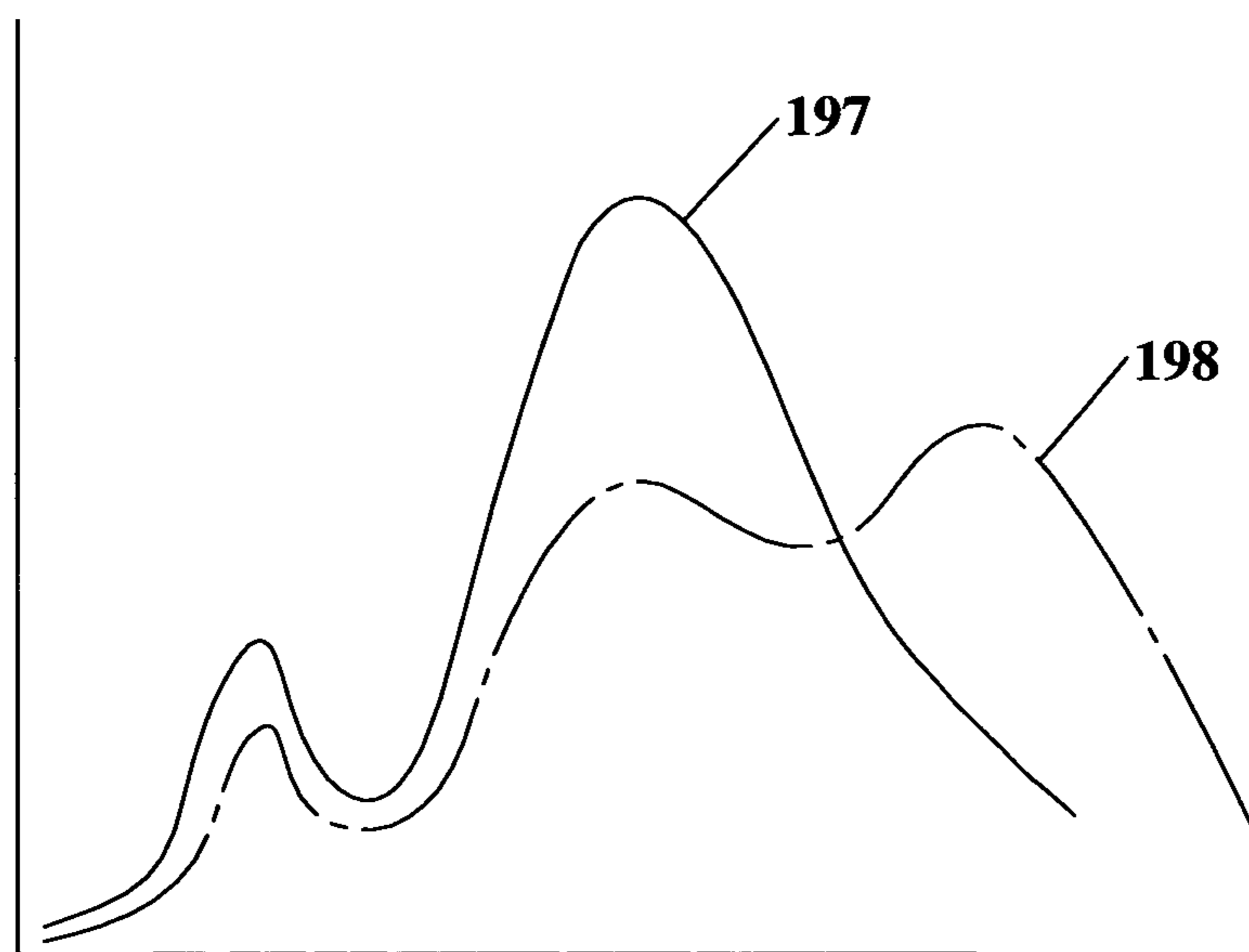

FIG. 16A

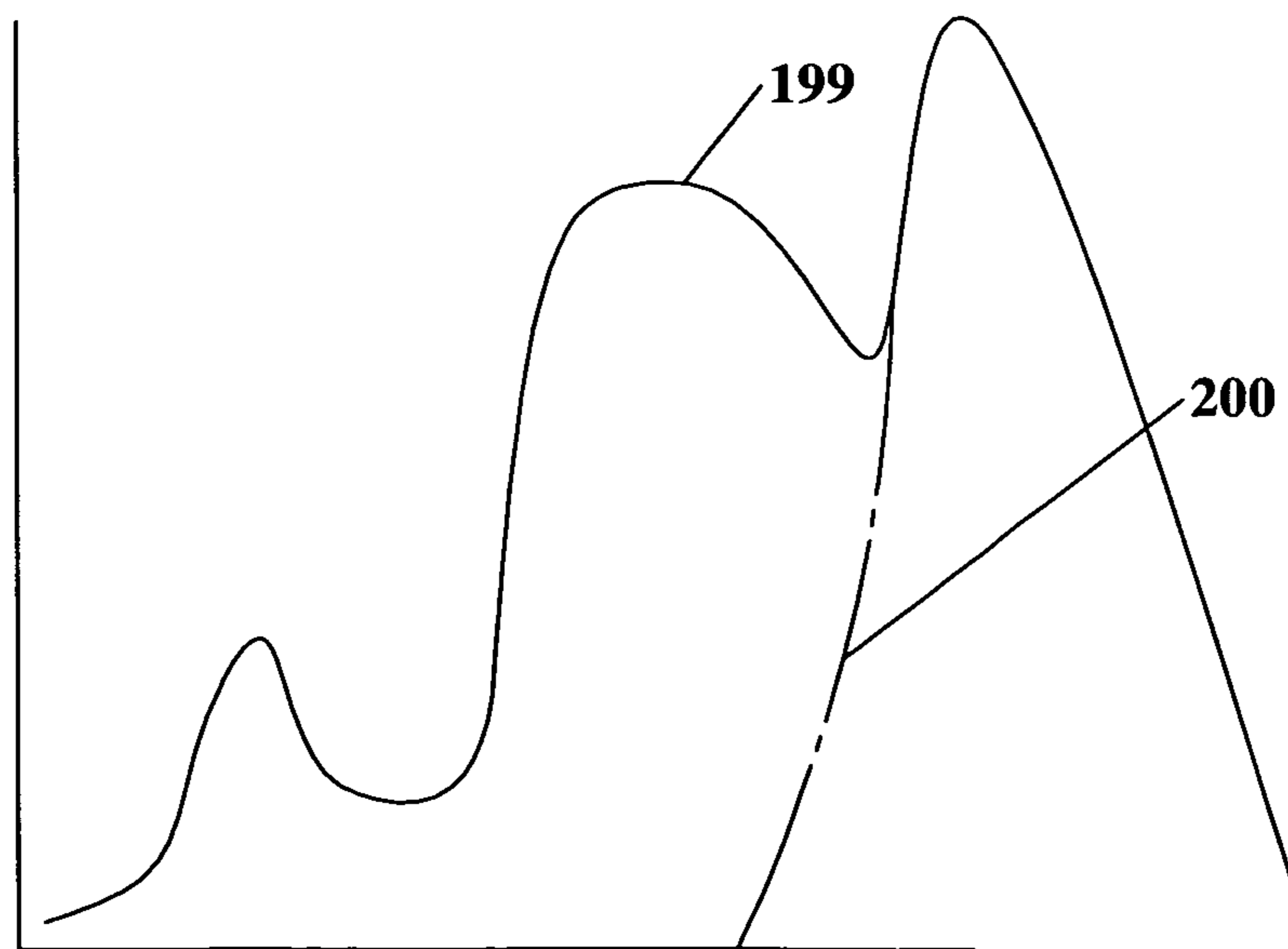

FIG. 16B

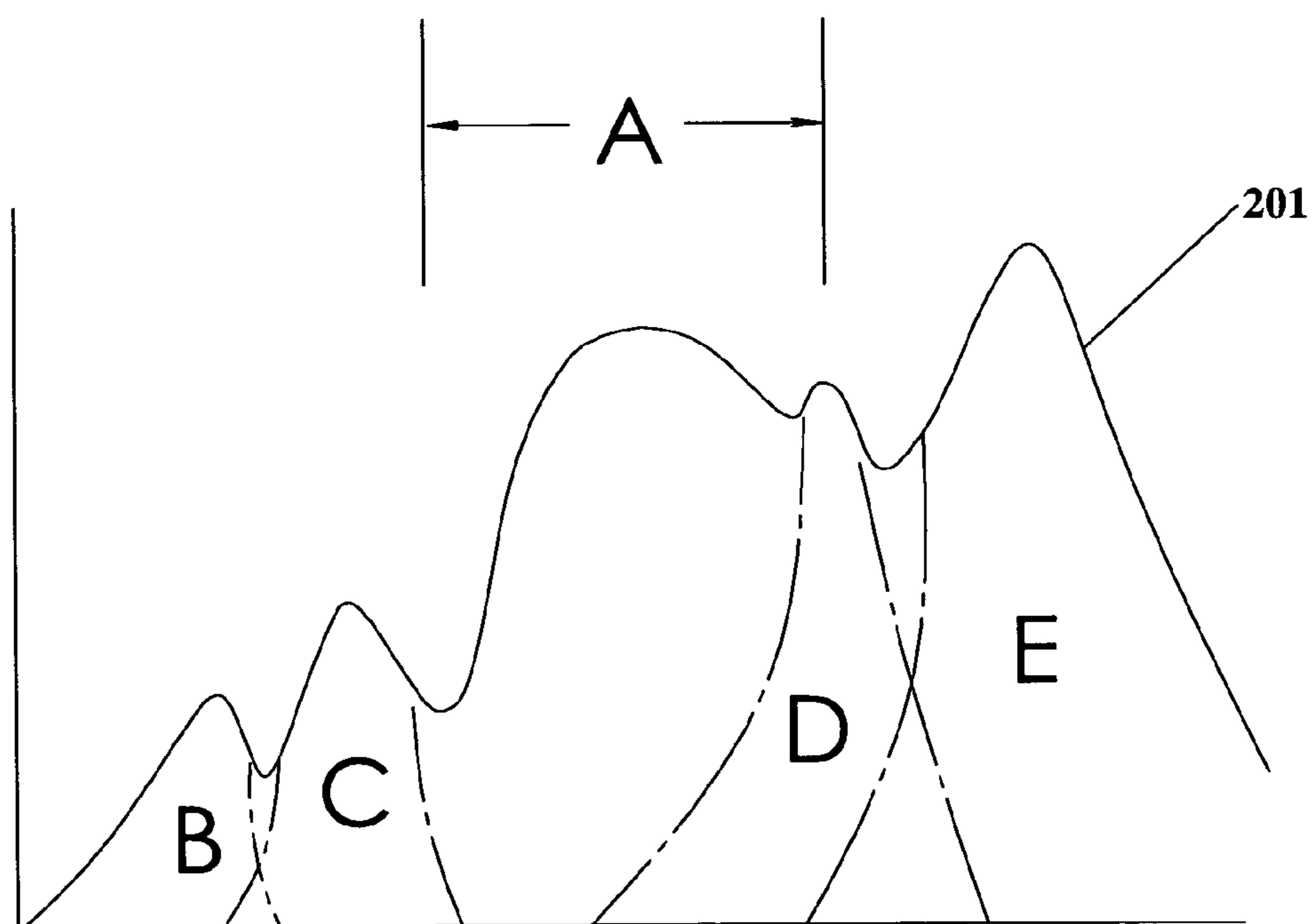

FIG. 17



FIG. 18A

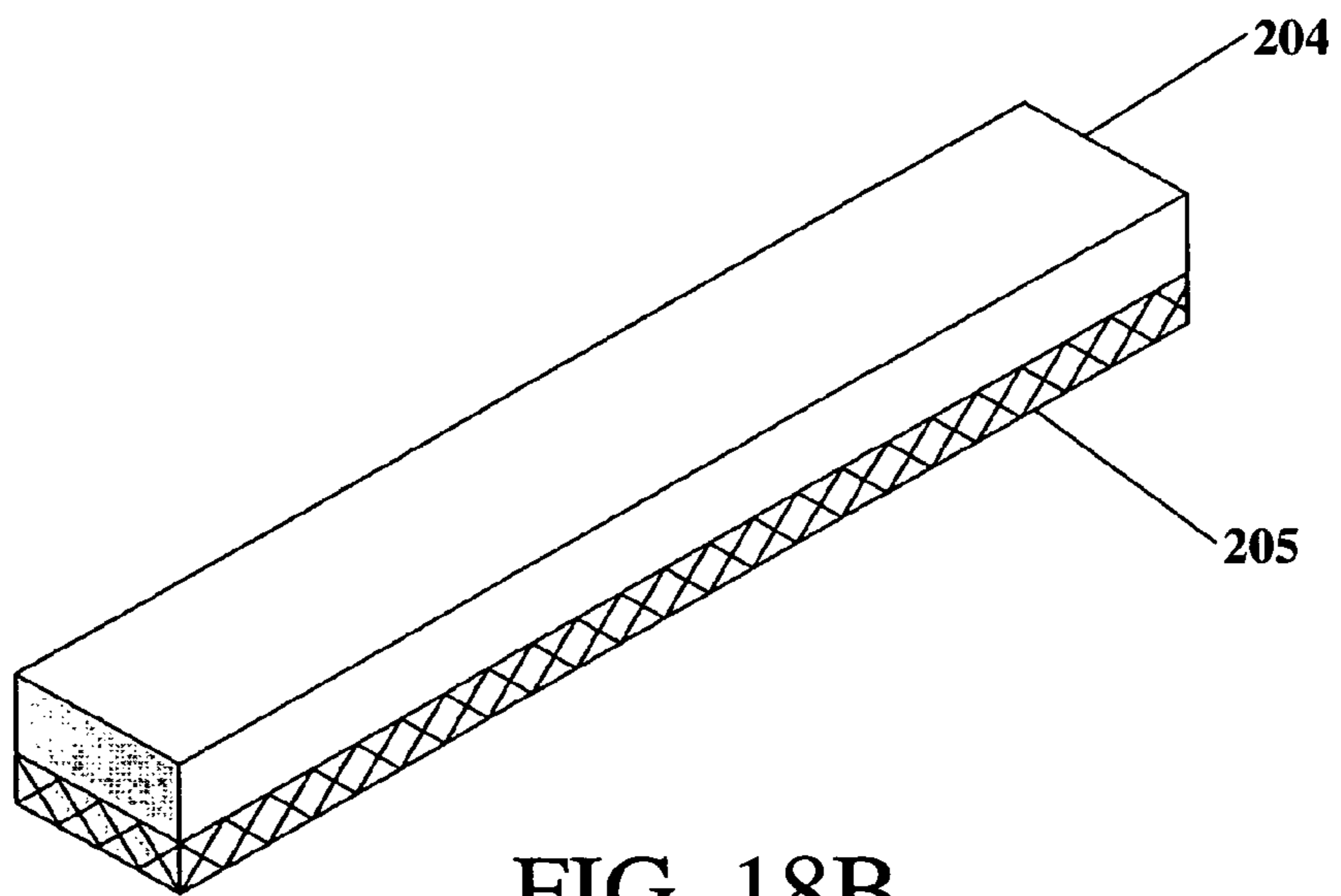

FIG. 18B

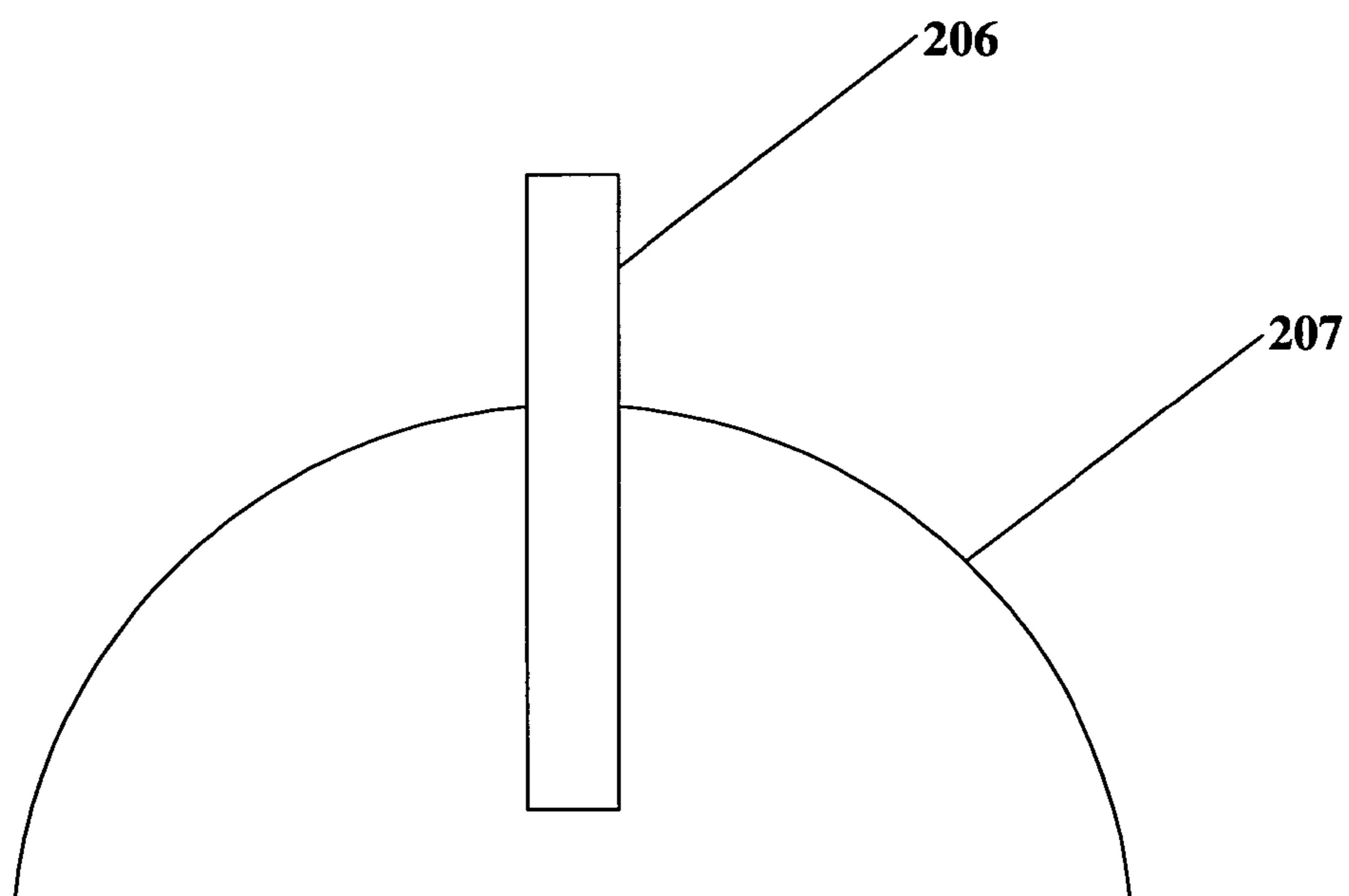

FIG. 19A

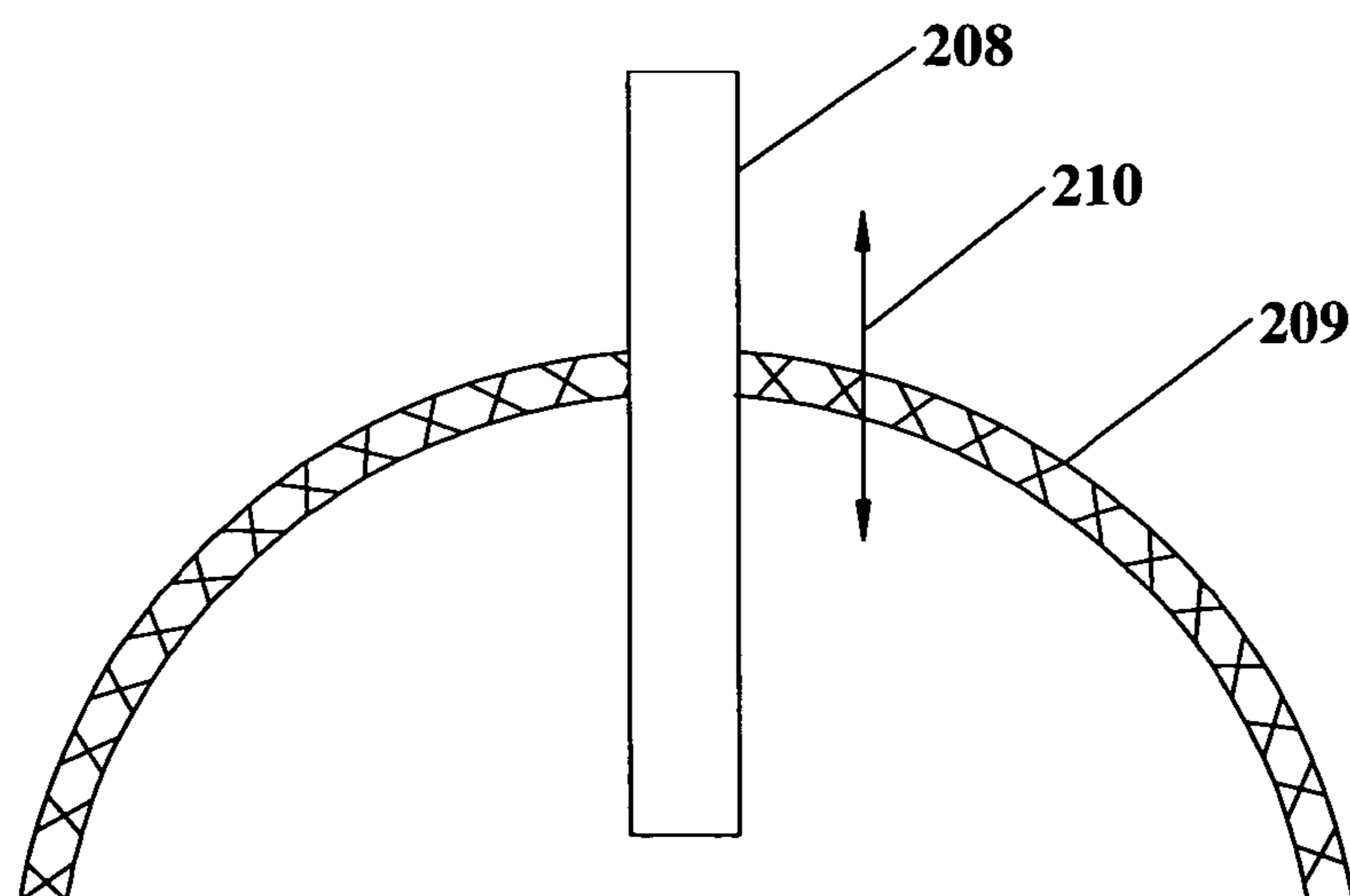
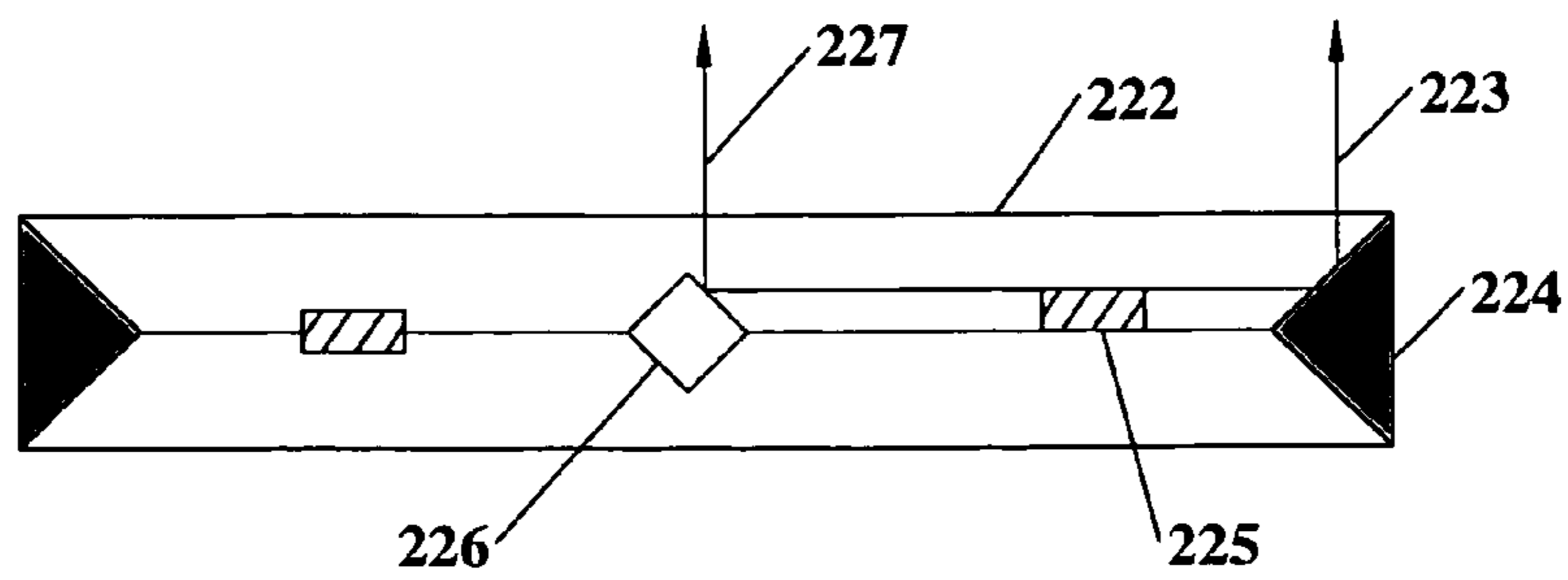
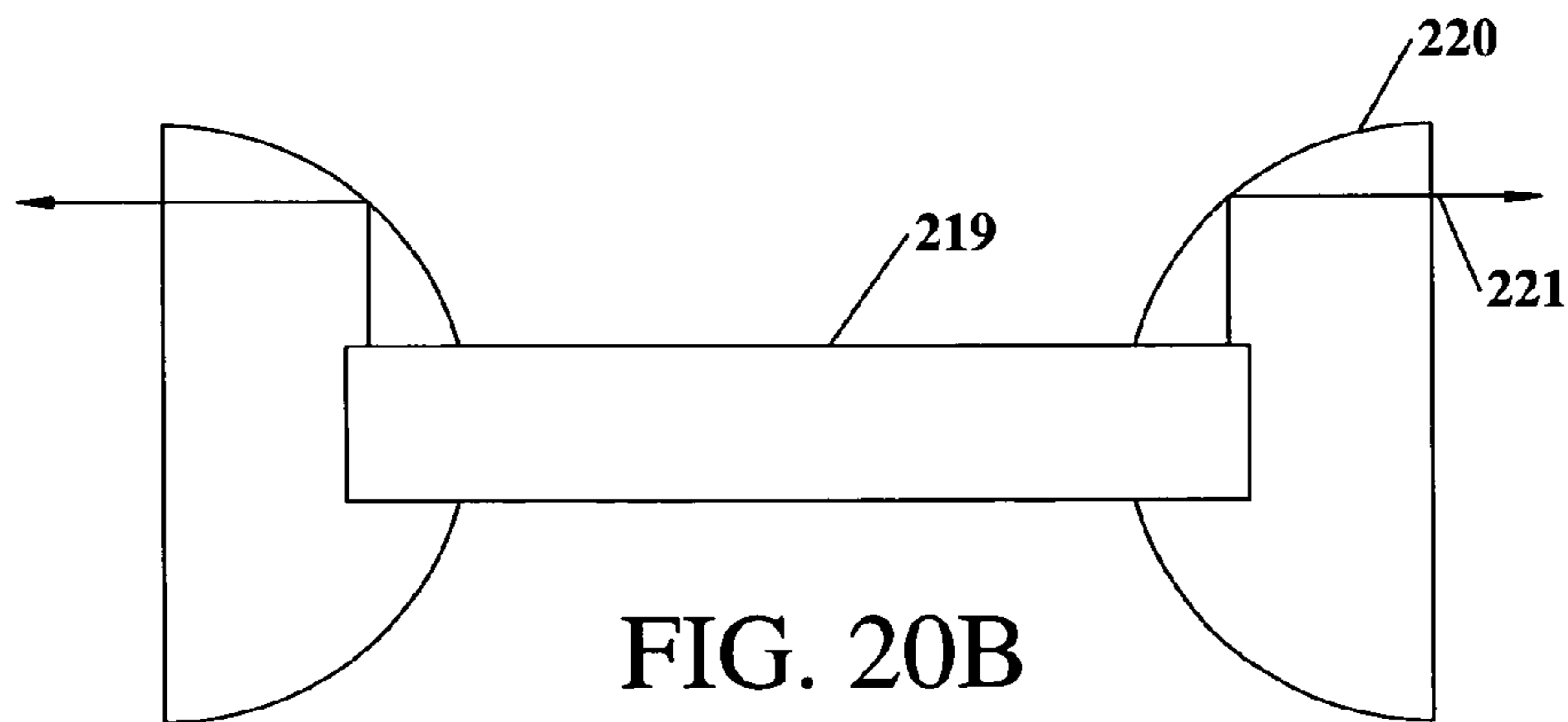
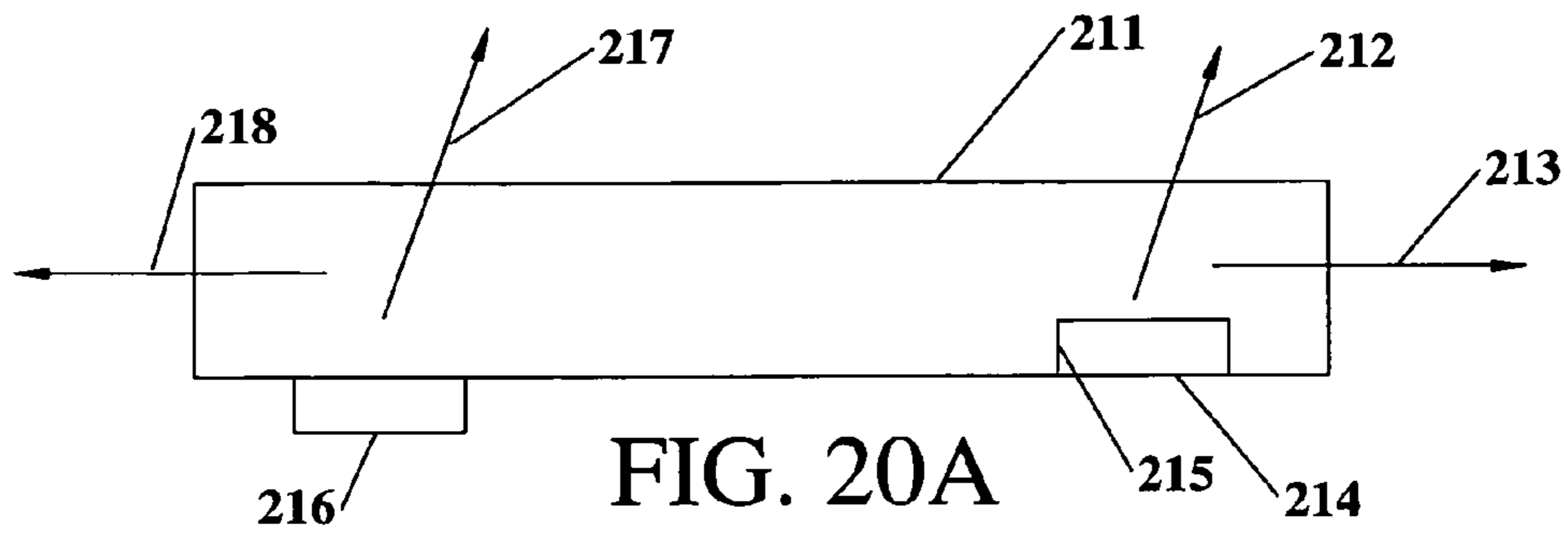

FIG. 19B



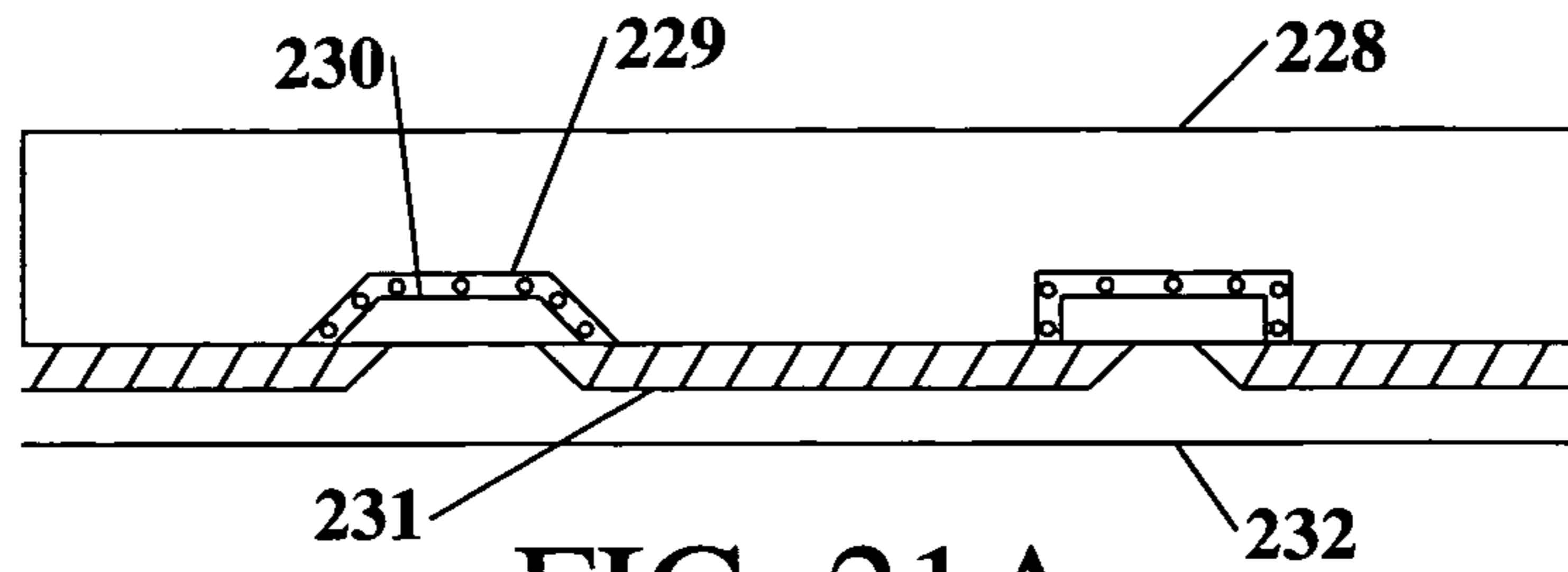

FIG. 21A

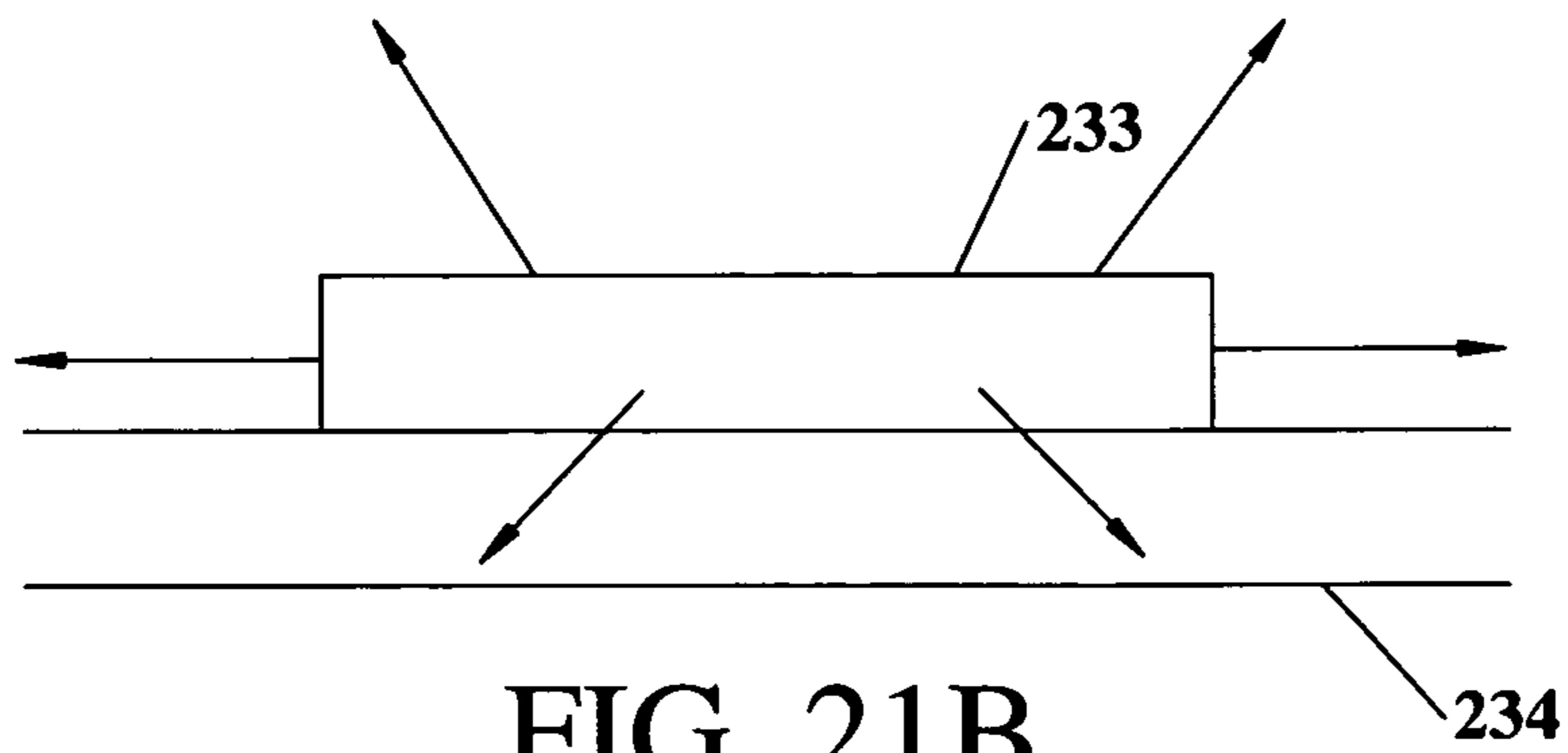

FIG. 21B

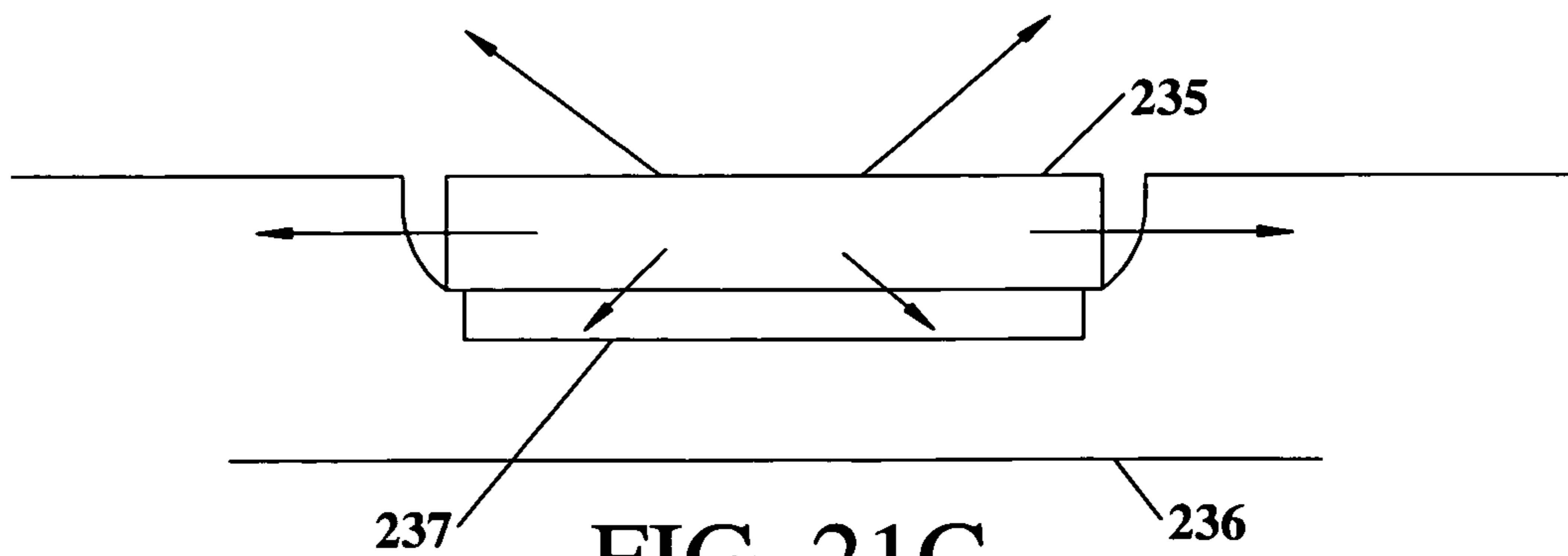

FIG. 21C

**SOLID STATE LIGHT SOURCES BASED ON
THERMALLY CONDUCTIVE LUMINESCENT
ELEMENTS CONTAINING INTERCONNECTS**

REFERENCE TO PRIOR APPLICATION

This application claims the benefit of U.S. Provisional Patent Application Ser. No. 61/574,925, which was filed on Aug. 11, 2011, which is herein incorporated by reference.

BACKGROUND OF THE INVENTION

This invention relates to solid state light sources based on LEDs mounted on or within thermally conductive luminescent elements, which provide both convective and radiative cooling. Low cost, self-cooling solid state light sources can be realized by also integrating the electrical interconnect of the LEDs and other semiconductor devices. The thermally conductive luminescent element can be used to completely or partially eliminate the need for any additional heatsinking means by efficiently transferring and spreading out the heat generated in LED and luminescent element itself over an area sufficiently large enough such that convective and radiative means can be used to cool the device.

Solid luminescent ceramic plates are disclosed in Born, U.S. Pat. No. 4,849,639, as scintillators for the conversion of shorter wavelength photons to longer wavelength photons. Born does not disclose the use of the ceramic plates to convert narrowband emission from solid state emitters into broadband visible light sources.

CeYag in ceramic, single crystal, and powder forms have been used since the early 1970s to convert blue wavelengths to yellow wavelengths for efficient coupling of flashlamp outputs into laser rods at Bell Labs and other institutions. Again, the use of these materials to convert blue/UV solid state emitters into broadband white light sources is not disclosed.

The formation of transparent and translucent luminescent YAG ceramics are disclosed in Cusano, U.S. Pat. No. 4,421,671, and Greskovich, U.S. Pat. No. 4,466,930. The use of these materials as scintillators, CRT faceplates, and X-ray screens is disclosed but not their use in solid state lighting.

The use of solid wavelength conversion elements to form self cooling light sources in which the solid wavelength conversion element is a ceramic, single crystal, composite and layered solid material is disclosed in Zimmerman, U.S. Pat. No. 7,285,791. Zimmerman discloses the use of solid wavelength conversion elements to form solid state light sources in U.S. Pat. No. 7,804,099. The use of high emissivity surfaces is not disclosed.

Mueller-Mach et al. in U.S. Pat. No. 6,696,703 disclose the deposition of a thin film phosphor directly on the LED die. However, as-deposited thin film phosphors have relatively poor wavelength conversion efficiency. A high-temperature annealing step is required in order to properly activate the phosphor. This annealing step can damage the semiconductor layers of the LED. In addition, the absorption cross-sections of most thin film phosphors are low, especially for blue and near ultraviolet (UV) excitations typically used within solid-state lighting. It is neither economical nor practical in most cases to create a sufficiently thick layer of luminescent material directly on the LED. Another drawback to depositing a phosphor directly on the LED die is that a large portion of the light generated within a deposited phosphor layer can be trapped due to total internal reflectance. The need therefore exists for a method to utilize high performance phosphors within an LED package such that the best phosphor can be

used efficiently (e.g. with sufficient quantity, minimal backscatter, and maximum light extraction). The need also exists for a method to fabricate high efficiency phosphors without damaging the LED semiconductor layers. In addition, high emissivity is not disclosed.

Another important aspect of phosphors relates to characterization and overall device efficiency. Phosphors are typically characterized in terms of quantum efficiency and Stokes shift losses. As an example, a powder phosphor layer is deposited on a glass surface and excited. The luminescence is measured as a function of excitation energy and the result is usually compared to a standard phosphor of known quantum efficiency. The losses associated with Stokes shift can be subtracted and the result would be the intrinsic quantum efficiency. Several problems exist with this method of characterization such as backscattered light, coating thickness variability and light trapping. In the case of phosphor powders, the majority of the generated light can escape from the phosphor particles due to their substantially spherical nature and to scattering centers located on or in the material itself. The main problem measuring the efficiency of phosphor powders is backscattering of the light from thick samples. For deposited phosphor films or grown phosphor boules, however, the problem of measuring the phosphor efficiency is affected by light extraction. The majority of the light generated in the phosphor can be trapped within the material itself due to total internal reflection. Several approaches have been used to solve the total internal reflection problem including various roughening techniques and shaping approaches. In these cases, the overall efficiency becomes as much a function of the extraction means as the conversion efficiency. Deposited phosphor films have the added complication of a secondary substrate material with its associated indices and losses.

Mayer et al. in U.S. Pat. No. 6,565,770 describe thin interference pigment flakes that can be made on a flexible substrate and then mechanically removed by flexing the substrate. The dichroic reflectors discussed are used in security enhancement on money and other decorative optical effects. The use of luminescent materials is discussed but is related to the formation of a particular optical effect such as UV illumination for security markings. No explanation for improving the output efficiency of LEDs or other light emitting devices is discussed and no device based on integrating the phosphor layer with the excitation source to form an efficient solid-state lighting element is disclosed.

The use of flake-like phosphors is also discussed by Aoki et al. in U.S. Pat. No. 6,667,574 for use in plasma displays, but the patent again lacks any reference to solid-state lighting applications or methods to enhance their output. In addition, the above two applications are very much cost driven because of the large areas typically required in making a plasma display or the marking of money or decorative items. In order to maximize the performance of these wavelength-converting materials high temperature processing is preferred.

Mueller-Mach et al. in U.S. Pat. No. 6,630,691 disclose a thin single-crystal phosphor substrate onto which an LED structure is fabricated by epitaxial growth techniques. However, single-crystal phosphor substrates are expensive and finding a single crystal phosphor substrate that has the proper lattice match to allow the growth of the LED structure can be difficult.

Ng et al. in US Patent Application No. 20050006659 disclose a planar sheet of a single-crystal phosphor that is placed over the output surface of an LED as a portion of a preformed transparent cap. However, single-crystal phosphor sheets must be grown by epitaxial processes or sliced from bulk single crystals of phosphor material. Single crystal phosphor

sheets are therefore too expensive for most practical applications. Planar sheets of polycrystalline phosphors are not disclosed in US Patent Application No. 20050006659. Bonding the planar sheet of a single-crystal phosphor directly to the surface of the LED to improve heat dissipation in the phosphor sheet is also not disclosed.

LEDs unlike conventional light sources such as incandescent bulbs cannot effectively cool themselves. As such additional heatsinking or cooling means are required to prevent overheating. This increases the cost of not only the light sources due to shipping costs and materials costs but also the fixtures that use those light sources. In general, the need exists for articles and means which allow LEDs to be used without the need for additional heatsinking means.

It is desirable to minimize the temperature difference between the junction or active region of the semiconductor device and the ambient atmosphere to effectively cool small semiconductor devices. It is also desirable to minimize the surface area needed to dissipate the heat generated by the semiconductor devices to the ambient atmosphere. While high thermal conductivity materials can be used to spread the heat out over a very large area, these high thermal conductivity materials come with the addition of significant weight and cost. In conventional LED devices several layers of interconnect exist between the LED die and the final light source. This approach is used because the lighting fixture manufacturers have historically not been required or had the capability to wirebond, flipchip attach or even solder components into their fixtures. Also the need to regularly replace light sources such as incandescent bulbs has led to a wide range of quick change interconnects like sockets and pin based connector. Lightweight self cooling solid state light sources would offer significant benefits to fixture manufacturers. Incandescent bulbs for instance are very lightweight generating over 1000 lumens while weighing only 50 grams and as such can be easily held in place using even simple pins and sockets. For the typical LED sources, this is not the case. The added weight of the heatsink and the need for a low resistance thermal connection between the LED package and the heatsink necessitates the use of complex multiple level interconnects. The need exists for LED light sources which are lightweight and easily incorporated into a wide range of lighting fixtures without the need for additional heatsinking or cooling means.

As is well known to those skilled in the art, phosphor conversion is typically used to broaden the narrow band emission of LEDs to more closely match the sun or incandescent spectrum. This is usually done via phosphor powders mixed into an organic matrix. Using this conventional approach, the heat generated in the phosphor powders is thermally isolated from the ambient by the organic matrix.

For example, blue InGaN LEDs are routinely coated with a thin organic layer containing phosphor powders. The organic material typically consists of a silicone or epoxy. As the LED efficiency and flux density has increased, more of the thermal losses are localized in the phosphor powders. Unfortunately, thermal conductivity of the luminescent layer is mainly determined by the thermal conductivity of the organic matrix material, which is typically around 0.1 W/m/K. Typically a 50 micron coating thickness for the luminescent organic layer prevents high scatter losses created by the index of refraction difference between the phosphor powder and organic matrix material. Conversely sufficient phosphor powder must be used to convert the shorter wavelength excitation to longer wavelength emission this is typically controlled by the loading level which is the ratio of the percentage of phosphor powder to the percentage of organic matrix material. A lower

loading level of the phosphor powder reduces the thermal conductivity and a higher loading level limits the thickness of coating due to scatter losses.

Generically it is difficult to remove a significant amount of heat out of the phosphor powders, let alone the LEDs themselves, while they are in a low thermal conductivity matrix. Their luminescent efficiency typically decreases as the phosphor powders get hotter. This luminescent inefficiency has spurred the development of remote phosphor approaches which reduce the thermal load on the phosphor powders by moving the phosphor powder farther away from the LED and thereby reducing the flux density per unit area on the powder. This remote phosphor approach however increases the source size, amount of phosphor powder required, forms a thermal barrier around the LEDs, and creates a large volume light source.

In addition, organic systems are susceptible to blue and UV radiation due to the photostability of the C—H bonds which define an organic system. Photostabilization of especially transparent optical systems under intense solarization has limited the long-term use of transparent organics (plastics) in greenhouse and other outdoors applications. The solar constant is approximate 1000 optical watts per square meter, with less than 10% of that having a wavelength short enough to photochemically attack the C—H bond. A typical blue LED in solid state lighting applications will output up to 1 optical watt per square millimeter of which virtually all the wavelengths emitted are capable of adversely affecting the C—H bonds of organic materials. These irradiation levels represent four order of magnitude higher flux densities than greenhouse films experience. Accordingly, inorganic solutions are more desirable than organic solutions for thermal conductivity and photostability standpoints.

All wavelength conversion materials and semiconductor devices exhibit temperature dependent efficiency curves. Thermal roll-off occurs for Ce:YAG around 150 degrees C. Alternately, AlInGaP red diodes and InGaN blue die both exhibit some roll-off as the junction temperature exceeds 100 degrees C. It therefore becomes critical that the heat generated within a solid state lighting system is transferred to the surrounding ambient using the lowest possible thermal resistance path. In the case of natural convection cooling the amount of heat that can be transferred to the surrounding ambient (air) is determined by the natural convection heat transfer coefficient, the area of the surface, and the temperature of the surface relative to the surrounding air or ambient.

Radiative cooling can also contribute to cooling solid state lighting devices if the temperature difference between the junction temperature and the radiating surface is minimized over a sufficiently large high emissivity surface area of the lighting device. Proposed solutions such as forced convection cooling, heatpipes, and even liquid cooling, either move the heat around or substantially increase the volume and weight of the light source. These solutions result in very low lumens/gram light sources.

Historically, light sources have cooled themselves as stated earlier. In the case of incandescent and fluorescent tubes, the glass envelope surrounding the sources, and the filament or arc itself transfers the excess heat generated via convection and radiation. An incandescent bulb glass envelope can exceed 150 degrees C. and a halogen's quartz envelope may exceed several hundred degrees celsius. Radiative power scales as the fourth power of the temperature. A naturally convectively cooled surface with a surface temperature of 50 degrees C. in a 25 degrees C. ambient will transfer only about 5% of its energy to the surrounding ambient radiatively. A naturally convectively cooled surface with a surface tempera-

ture of 100 degrees C. can transfer 20% of its energy to the surrounding ambient radiatively. The typical LED junction temperature for high powered devices can be over 120 degrees C. and still maintain excellent life and efficiency. For surfaces with temperatures less than 120 degrees C. the majority of the radiated energy is in the infrared with a wavelength greater than 8 microns.

The emissivity of the materials in the infrared varies greatly. Glass has an emissivity of approximately 0.95 while aluminum oxide may be as low as 0.23. Organics such as polyimides can have fairly high emissivity in thick layers. This however will negatively affect the transfer of heat due to the low thermal conductivity of organics.

In order to maximize heat transfer to the ambient atmosphere, the need exists for luminescent thermally conductive materials which can effectively spread the heat generated by localized semiconductor and passive devices (e.g. LEDs, drivers, controller, resistors, coils, inductors, caps etc.) to a larger surface area than the semiconductor die via thermal conduction and then efficiently transfer the heat generated to the ambient atmosphere via convection and radiation. At the same time, these luminescent thermally conductive materials must efficiently convert at least a portion of the LED emission to another portion of the visible spectrum to create a self cooling solid state light source with high L/W efficiency and good color rendering.

Heat generated within the LEDs and phosphor material in typical solid state light sources is transferred via conduction means to a much larger heatsink usually made out of aluminum or copper. The temperature difference between the LED junction and heatsink can be 40 to 50 degrees C. The temperature difference between ambient and heatsink temperature is typically very small given the previously stated constraints on the junction temperatures of LEDs. This small temperature difference not only eliminates most of the radiative cooling but also requires that the heatsink be fairly large and heavy to provide enough surface area to effectively cool the LEDs. This added weight of the heatsink increases costs for shipping, installation and in some cases poses a safety risk for overhead applications.

Ideally, like incandescent, halogen, sodium, and fluorescent light sources, the emitting surface of the solid-state light source would also be used to cool the source. Such a cooling source would have an emitting surface that was very close to the temperature of the LED junctions to maximize both convective and radiative cooling. The emitting surface should be constructed of a material that exhibited sufficient thermal conductivity to allow for the heat from small but localized LED die to be spread out over a sufficiently large enough area to effectively cool the LEDs.

This invention discloses thermally conductive luminescent elements within solid state light sources which overcome these issues.

SUMMARY OF THE INVENTION

This invention relates to solid state light sources based on LEDs mounted on or within thermally conductive luminescent elements. The thermally conductive luminescent elements provide a substantial portion of the cooling of the LEDs using both convective and radiative cooling from the emitting surfaces. Electrical interconnect of the LEDs and other semiconductor devices based on opaque and/or transparent conductors create low cost self-cooling solid state light sources. The low cost self-cooling solid state light sources can have printed on, thick film printed silver conductors with a reflectivity greater than 30%.

Briefly, and in general terms, the self cooling light source of the invention comprises at least one light-emitting diode (LED) die; and at least one thermally conductive luminescent element. The luminescent element includes an electrical interconnect and performs multiple functions: as a wavelength converter, converting at least a portion of the light emitted by said LED die to a different wavelength range, as an optical waveguide for light emitted by said LED die, and as a heat spreading element, spreading heat generated by said LED die over a greater cross-sectional area. Finally the luminescent element provides a high emissivity layer, for optimal coupling of emitted light from the light source.

The thermally conductive luminescent element can be used to completely or partially eliminate the need for any additional heatsinking means by efficiently transferring and spreading out the heat generated in LED and luminescent element itself over an area sufficiently large enough such that convective and radiative means can be used to cool the device. In other words, the surface emitting light also convectively and radiatively cools the device. The thermally conductive luminescent element also provides for the efficient wavelength conversion of at least a portion of the radiation emitted by the LEDs.

The present invention may also be defined as a self cooling solid state light source comprising at least one light-emitting diode (LED) die and at least one thermally conductive luminescent element bonded to the at least one LED die; wherein heat is transmitted from the light source in basically the same direction as emitted light. More specifically, light is emitted from the LED die principally in a direction through the at least one luminescent element, and heat generated in the light source is transmitted principally in the same direction as the direction of light emission. Heat is dissipated from the light source by a combination of radiation, conduction and convection from the at least one luminescent element, without the need for a device heat sink.

Optionally, the luminescent thermally conductive element can provide light spreading of at least a portion of the radiation from the LEDs and/or radiation converted by the thermally conductive luminescent elements via waveguiding. A thermally conductive luminescent element acts as a waveguide with alpha less than 10 cm⁻¹ for wavelengths longer than 550 nm. In this case, the LEDs with emission wavelengths longer than 550 nm can be mounted and cooled by the thermally conductive luminescent elements and also have at least a portion of their emission efficiently spread out via waveguiding within the thermally conductive luminescent element as well.

Thermally conductive luminescent elements with InGaN and AlInGaP LEDs can convert at least a portion of the InGaN spectrum into wavelengths between 480 and 700 nm. Single crystal, polycrystalline, ceramic, and/or flamesprayed Ce:YAG, Strontium Thiogallate, or other luminescent materials emitting light between 480 and 700 nm and exhibiting an alpha below 10 cm⁻¹ for wavelengths between 500 nm and 700 nm can be a thermally conductive solid luminescent light spreading element.

The mounting of InGaN and AlInGaP LEDs can form solid state extended area light sources with correlated color temperatures less than 4500 K and efficiencies greater than 50 L/W and optionally color rendering indices greater than 80 based on these thermally conductive light spreading luminescent elements.

One embodiment of this invention is a luminescent thermally conductive translucent element having a thermal conductivity greater than 1 W/m/K consisting of one or more of the following materials, alumina, ALN, spinel, zirconium

oxide, BN, YAG, TAG, and YAGG. Optionally, electrical interconnects maybe formed on at least one surface of the luminescent thermally conductive translucent element to provide electrical connection to the LED.

The luminescent thermally conductive element can have a thermal conductivity greater than 1 W/mK and have an emissivity greater than 0.2. A self cooling solid state light source can have at least one luminescent thermally conductive element with a thermal conductivity greater than 1 W/m/K and an emissivity greater than 0.2. A self cooling solid state light source can have an average surface temperature greater than 50 degrees C. and a luminous efficiency greater than 50 L/W. Optionally, a self-cooling solid state light source can have an average surface temperature greater than 50 degrees C. and a luminous efficiency greater than 50 L/W containing at least one luminescent thermally conductive element with a thermal conductivity greater than 1 W/m/K and an emissivity greater than 0.2. A self-cooling solid state light source can dissipate greater than 0.3 W/cm² via natural convection cooling and radiation cooling.

Luminescent thermally conductive elements can be formed via the following methods: crystal growth, sintering, coating, fusible coating, injection molding, flame spraying, sputtering, CVD, plasma spraying, melt bonding, and pressing. Pressing and sintering of oxides with substantially one phase will improve translucency based on a luminescent powder. Alternately, a translucent element with a thermal conductivity greater the 1 W/m/K and an alpha less than 10 cm⁻¹ can be coated with a luminescent layer formed during the sintering process or after the sintering process. Single crystal or polycrystalline materials, both luminescent and non-luminescent, can be the thermally conductive luminescent element. Specifically TPA (transparent polycrystalline alumina), spinel, cubic zirconia, quartz, and other low absorption thermally conductive materials with a luminescent layer can be formed during or after fabrication of these materials. Techniques such as pressing, extruding, and spatial flame spraying can form near net shape or finished parts. Additional luminescent layers can be added to any of these materials via dip coating, flame spraying, fusing, evaporation, sputtering, CVD, laser ablation, or melt bonding. Controlled particle size and phase can improve translucency.

Coatings can improve the environmental and/or emissivity characteristics of the self-cooling light source, particularly if the coating is a high emissivity coating with and without luminescent properties. Single crystal, polycrystalline, ceramic, coating layers, or flame sprayed can be used both as a coating and as the bulk material Ce:YAG, with a high emissivity or environmental protective coating. In particular, polysiloxanes, polysilazanes and other transparent environmental overcoats can be applied via dip coating, evaporative, spray, or other coating methods, applied either before or after the attachment of the LEDs. Additional luminescent materials can be added to these overcoats such as but not limited to quantum dots, luminescent dyes (such as Eljen wavelength shifter dyes), and other luminescent materials.

Wireless power transfer elements, power conditioning element, drive electronics, power factor conditioning electronics, infrared/wireless emitters, and sensors can be integrated into the self-cooling solid state light source.

A self-cooling solid-state light source can have a luminous efficiency greater than 50 L/W at a color temperature less than 4500K and a color rendering index greater than 70. The self-cooling solid-state light source can have a surface temperature greater than 40 degrees C., convectively and radiatively cooling more than 0.3 W/cm² of light source surface area, and having a luminous efficiency greater than 50 L/W.

A self-cooling solid-state light source can have a luminous efficiency great than 50 L/W at a color temperature less than 4500K and a color rendering greater than 85 containing both blue and red LEDs. At least one luminescent thermally conductive element with an alpha less than 10 cm⁻¹ for wavelengths longer than 500 nm is used in the self cooling solid state light source containing at least one blue and at least one LED with emission wavelengths longer than 500 nm. Additional luminescent materials in the form of coatings and/or elements including, but not limited, to phosphor powders, fluorescent dies, wavelength shifters, quantum dots, and other wavelength converting materials, can further improve efficiency and color rendering index.

Aspect ratios and shapes for the solid state light source can be, including but not limited to, plates, rods, cylindrical rods, spherical, hemispherical, oval, and other non-flat shapes. Die placement can mitigate edge effects and form more uniform emitters. Additional scattering, redirecting, recycling, and imaging elements can be attached to and/or in proximity to the solid state light source designed to modify the far field distribution. Additional elements can be attached to the solid state light source with a thermally conductivity greater than 0.1 W/m/K such that additional cooling is provided to the solid state light source via conduction of the heat generated within the solid state light source to the additional element and then to the surrounding ambient. An external frame can provide mechanical support, can be attached to the solid state light source, and/or can provide an external electrical interconnect. Multiple solid state sources arranged with and without additional optical elements can generate a specific far field distribution. In particular, multiple solid state sources can be arranged non-parallel to each other such that surface and edge variations are mitigated in the far field. A separation distance between solid state light sources faces of greater than 2 mm is preferred to facilitate convective cooling. Mounting and additional optical elements can enhance convective cooling via induced draft effects.

In this invention, thermally conductive luminescent elements on to which semiconductor devices are mounted are used to effectively spread the heat out over a sufficient area with a low enough thermal resistance to effectively transfer the heat generated by the semiconductor devices and the thermally conductive luminescent element itself to the surrounding ambient by both convection and radiative means. In this invention, the surface emitting light convectively and radiatively cools the device.

The thermally conductive luminescent element also provides for the efficient wavelength conversion of at least a portion of the radiation emitted by the LEDs. Optionally, the luminescent thermally conductive element can provide light spreading of at least a portion of the radiation from the LEDs and/or radiation converted by the thermally conductive luminescent elements. The thermally conductive luminescent elements act as waveguides with alpha less than 10 cm⁻¹ for wavelengths longer than 550 nm. In this case the LEDs with emission wavelengths longer than 550 nm can be mounted and cooled by the thermally conductive luminescent elements and also have at least a portion of their emission efficiently spread out via waveguiding within the thermally conductive luminescent element as well.

Disclosed is a self cooling solid state light source containing an optically transmitting thermally conductive element with a surface temperature greater than 50 degree C. and a surface area greater than the semiconductor devices mounted on the optically transmitting thermally conductive element. Even more preferably a self cooling solid state light source containing at least one optically transmitting thermally con-

ductive element with a surface temperature greater than 100 degrees C. and a surface area greater than the surface area of the mounted semiconductor devices. Most preferred is a self cooling solid state light source containing at least one optically transmitting thermally conductive luminescent element with an average thermal conductivity greater than 1 W/m/K. As an example, YAG doped with 2% Cerium at 4 wt % is dispersed into an alumina matrix using spray drying. The powders are pressed into a compact and then vacuum sintered at 1500 degrees C. for 8 hours, followed by hot isostatic pressing at 1600 degrees C. for 4 hours under argon. The material is diamond saw diced into 1 mm thick pieces which are 1/2 inch x 1 inch in area. The parts are laser machined to form interconnect trenches into which silver paste is screen printed and fired. The fired silver traces are then lapped to form smooth surface to which direct die attach LED die are soldered. Pockets are cut using the laser such that two pieces can be sandwiched together thereby embedding the direct die attach LED die inside two pieces of the ceramic CeYag/alumina material. In this manner, a self cooling light source is formed. The direct die attached LED are electrically interconnected via the silver traces and thermally connected to the ceramic CeYag/alumina material. The heat generated within the direct die attach LEDs and the ceramic CeYag/alumina material is spread out over an area greater than the area of the LEDs. In this example, power densities greater than 1 W/cm² can be dissipated while maintaining a junction temperature less than 120 degrees C. and surface temperature on the ceramic CeYag/alumina material of 80 to 90 degrees C. based on natural convection and radiative cooling. As such a 1/4 inch x 1/2 inch solid state light source can emit over 100 lumens without any additional heatsinking or cooling means.

Materials with emissivities greater than 0.3 are preferred to enhance the amount of heat radiated of the surface of the solid state light source. Even more preferable emissivity greater than 0.7 for surface temperatures less than 200 degrees C. A naturally convectively cooled surface with a natural convection coefficient of 20 W/m²/k with a surface temperature of 50 degrees C. in a 25 degrees C. ambient will transfer about 25% of its energy to the surrounding ambient radiatively if the surface emissivity is greater than 0.8 and can dissipate approximately 0.08 W/cm² of light source surface area. A similar naturally convectively cooled surface with a surface temperature of 100 degrees C. can transfer 30% of its energy to the surrounding ambient radiatively and dissipate greater than 0.25 watts/cm² of surface area. A similar naturally convectively cooled surface with a surface temperature of 150 degrees C. can transfer 35% of the heat radiatively and dissipate greater than 0.4 watts/cm². Given that solid state light sources can approach 50% electrical to optical conversion efficiency and that the typical spectral conversion is 300 lumens/optical watt using this approach a self cooling solid state light source can emit 75 lumens for every 1.0 cm² of light source surface area. As an example, a 1/4 inch x 1/2 inch x 2 mm thick self cooling light stick can generate more than 150 lumens while maintaining a surface temperature less than 100 degrees C. The typical LED junction temperature for high powered devices can be over 120 degrees C. and still maintain excellent life and efficiency. For surfaces with temperatures less than 120 degrees C. the majority of the radiated energy is in the infrared with a wavelength greater than 8 microns. As such high emissivity coatings, materials, and surfaces which are substantially transparent in the visible spectrum are preferred embodiments of self cooling light sources.

The emissivity of the materials in the infrared varies greatly. Glass has an emissivity of approximately 0.95 while aluminum oxide may be between 0.5 and 0.8. Organics such

as polyimides can have fairly high emissivity in thick layers. This however will negatively affect the transfer of heat due to the low thermal conductivity of organics. As such high thermal conductivity high emissivity materials and coating are preferred. High emissivity/low visible absorption coatings are described in J. R. Grammer, "Emissivity Coatings for Low-Temperature Space Radiators", NASA Contract NAS 3-7630 (30 Sep. 1966). Various silicates are disclosed with emissivity greater than 0.85 and absorptions less than 0.2.

In order to maximize heat transfer to the ambient atmosphere, the need exists for luminescent thermally conductive materials which can effectively spread the heat generated by localized semiconductor and passive devices (e.g. LEDs, drivers, controller, resistors, coils, inductors, caps etc.) to a larger surface area than the semiconductor die via thermal conduction and then efficiently transfer the heat generated to the ambient atmosphere via convection and radiation. At the same time, these luminescent thermally conductive materials must efficiently convert at least a portion of the LED emission to another portion of the visible spectrum to create a self cooling solid state light source with high L/W efficiency and good color rendering. Conventional wavelength converters in both solid and powder form are substantially the same size as the LED die or semiconductor devices. This minimizes the volume of the luminescent material but localizes the heat generated within the luminescent element due to stokes losses and other conversion losses. In present day solid state light sources approximately 50% of the heat generated is within the luminescent material. By using a thermally conductive luminescent element with low dopant concentration which also acts as a waveguide to the excitation light emitted by the LEDs the heat generated by the luminescent conversion losses can be spread out over a larger volume. In addition a more distributed light source can be generated rather localized point sources as seen in conventional LED packages. In this manner the need for addition diffusing and optical elements can be eliminated or minimized. As such the use of luminescent thermally conductive elements with surface area greater than the semiconductor devices mounted on the luminescent elements is a preferred embodiment.

Heat generated within the LEDs and phosphor material in typical solid state light sources is transferred via conduction means to a much larger heatsink usually made out of aluminum or copper. The temperature difference between the LED junction and heatsink can be 40 to 50 degrees C. The temperature difference between ambient and heatsink temperature is typically very small given that significant temperature drop occurs from the LED junction and the heatsink surfaces. This small temperature difference not only eliminates most of the radiative cooling but also requires that the heatsink be fairly large and heavy to provide enough surface area to effectively cool the LEDs. The larger the heatsink, the larger the temperature drop between the LED junction and the surface of the heatsink fins. For this reason, heatpipes and active cooling is used to reduce either the temperature drop or increase the convective cooling such that a smaller heatsink volume can be used. In general, the added weight of the heatsink and/or active cooling increases costs for shipping, installation, and in some cases poses a safety risk for overhead applications.

Ideally, like incandescent, halogen, sodium, and fluorescent light sources, the emitting surface of the solid-state light source would also be used to cool the source. Such a cooling source would have an emitting surface that was very close to the temperature of the LED junctions to maximize both convective and radiative cooling. The emitting surface should be constructed of a material that exhibited sufficient thermal

11

conductivity to allow for the heat from small but localized LED die to be spread out over a sufficiently large enough area to effectively cool the LEDs. In this invention this is accomplished by spreading the heat generated within the luminescent element out over a larger volume, using a thermal conductivity luminescent element that spreads the heat generated in the semiconductor devices used via conduction over a larger surface area than the semiconductor devices, and maximizing the radiative and convective cooling by high emissivity coatings, increased surface area, and higher surface temperatures created by efficient coupling of the heat to the surface of the self cooling light source.

BRIEF DESCRIPTION OF DRAWINGS

FIGS. 1A and 1B depict side views of prior art vertical and flip chip mounted LED packages and thermal schematics where the optical emission is substantially in the opposite direction of the heat removal.

FIGS. 2A, 2B and 2C depict side views of self-cooling solid state light sources using luminescent thermally conductive luminescent elements and interconnects with thermal schematics of the present invention.

FIGS. 3A, 3B and 3C depict side views of a self-cooling solid state light source with multiple die of the present invention.

FIGS. 4A, 4B and 4C depict side views of printed electrical interconnects on luminescent thermally conductive elements for various LED die types of the present invention.

FIGS. 5A, 5B, 5C and 5D depict side views of various shapes of wavelength conversion elements of the present invention.

FIGS. 6A and 6B depict a side view of two different mountings for LEDs on wavelength conversion elements of the present invention.

FIGS. 7A, 7B and 7C depict side views of printed interconnects on LED die of the present invention.

FIGS. 8A, 8B, 8C and 8D depict side views of various environmental seals for self cooling light sources of the present invention.

FIGS. 9A and 9B depict side views of die shaping for enhanced dual sided extraction of the present invention.

FIGS. 10A and 10B depict a side view and a graph of blue and red die in wavelength conversion elements of the present invention.

FIG. 11 depicts a top view of a three pin self cooling light source of the present invention.

FIG. 12 depicts a top view of a self cooling light source with an integrated driver of the present invention.

FIGS. 13A and 13B depict a side view and a perspective view of a self cooling light source with additional cooling means of the present invention.

FIG. 14 depicts a top view of a self cooling light source with thermally isolated sections of the present invention.

FIG. 15 depicts a top view of a self cooling light source with separate drive scheme for blue and red die of the present invention.

FIGS. 16A and 16B depict graphs of subtractive red phosphor and additive red LED of the present invention.

FIG. 17 depicts a graph of the spectrum from a self cooling light source with cyan and yellow LEDs of the present invention.

FIGS. 18A and 18B depict a side view and a perspective view of various shapes with luminescent coatings of the present invention.

FIGS. 19A and 19B depict side views of optics for self cooling light source of the present invention.

12

FIGS. 20A, 20B, and 20C depict side views of means of modifying the far field optical patterns of self cooling light sources of the present invention.

FIGS. 21A, 21B, and 21C depict side views of a light emitting patch source and its use with waveguiding materials of the present invention.

DETAILED DESCRIPTION OF DRAWINGS

FIG. 1A depicts a prior art vertical LED die 3 mounted on a substrate 4. The vertical LED die 3 is typically coated with an inorganic/organic matrix 7 consisting of phosphor powder such as, but not limited to, Ce:YAG in a silicone resin material. The wire bond 2 is used to electrically connect vertical LED die 3 to interconnect 5 which is then coated with the inorganic/organic matrix 7. The other side of vertical LED die 3 is contacting interconnect 6 usually via eutectic solder or conductive adhesives. A lens 1 is further attached to substrate 4 to environmentally seal the assembly, enhance light extraction from vertical LED die 3, and modify the far field optical pattern of the light emitted by the device. In this case, emitted rays 9 are substantially traveling in the opposite direction of the heat ray 8.

As shown in the thermal schematic in FIG. 1A, cooling of the inorganic/organic matrix 7 occurs almost exclusively via thermal conduction through the vertical LED die 3 and into the substrate 4 via interconnect 6. The heat generated within inorganic/organic matrix 7 due to Stokes losses and scattering absorption is thermally conducted to the vertical LED die 3 at a rate determined by the thermal resistance determined by the bulk thermal conductivity of the inorganic/organic matrix 7. As shown in the simplified thermal schematic, the average temperature of the inorganic/organic matrix 7 is determined by the thermal resistance $R(\text{phosphor/encapsulant})$ and T_2 the average temperature of the vertical LED die 3. In order for heat generated within the inorganic/organic matrix 7 to be dissipated to the ambient, it must move the thermal resistance of LED die 3 (R_{LED}) and substrate 4 ($R_{Package}$) before it can be dissipated to the ambient. This is a simplified thermal schematic which lumps bulk and interface thermal resistances and spatial variations within the device. But in general, heat generated within the inorganic/organic matrix 7 must be dissipated mainly through the vertical LED die 3 due to low thermal conductivity of the other materials (e.g. Lens) which surround inorganic/organic matrix 7. Additional heatsinking means can further increase the surface area using metal, composite, or ceramic elements to enhance the dissipation of heat to ambient but the flow of heat is still basically the same. The lens 1 acts as an extraction element for the emitted light rays 9 but also acts as a barrier to thermal rays 8. Typically constructed of silicone or epoxy resins with thermal conductivity less than 0.1 W/m/K, Lens 1 acts as a thermal insulator. Lens 1 also can limit thermal radiation from vertical LED 3 and inorganic/organic matrix 7 due to low emissivity. In general this design requires that approximate 50% of the isotropic emission from the active region within vertical LED 1 must be reflected off some surface within the device and that the far field output of the device be substantially directional or lambertian in nature. Even with the use of highly reflective layers, this represents a loss mechanism for this approach. These extra losses are associated with the added pathlength that the optical rays must go through and multiple reflections off the back electrodes. This added pathlength and reflections, which are required to extract the light generated in the active region of vertical LED 1, fundamentally reduces the efficiency of the LED based on the absorption losses of the LED itself. A significant portion of the light generated within the inorganic/

13

organic matrix **7** must also pass through and be reflected by vertical LED **1**. Since vertical LED **1** is not a lossless reflector, the added pathlength of these optical rays also reduce overall efficiency.

FIG. **1B** depicts a prior art flipchip mounted LED **15**. Solder or thermocompression bonding attaches flipchip mounted LED **15** via contacts **16** and **21** to interconnects **17** and **18** respectively on substrate **19**. Luminescent converter **14** may be an inorganic/organic matrix as discussed in FIG. **1A** or solid luminescent element such as a Ce:YAG ceramic, single crystalline Ce:YAG, polycrystalline Ce:YAG or other solid luminescent materials as known in the art. In either case, the same cooling deficiency applies with this design. Virtually all the cooling of the luminescent converter **14** must be through the flipchip mounted LED **15**. Again, emission rays **12** travel in a direction substantially opposite to thermal rays **13** and once again approximately 50% the isotropic emission of the active region of the flipchip mounted LED **15** must be redirected within the device requiring the use of expensive metals like Ag, specialized coating methods and even nanolithography as in the case of photonic crystals.

The formation of contacts which are both highly reflective over a large portion of the LED die area and still forms a low resistivity contact has been a major challenge for the industry due to reflectivity degradation of Ag at the temperature typically required to form a good ohmic contact. This high light reflectivity and low electrical resistivity leads to added expense and efficiency losses. Because both the contacts must be done from one side typically an underfill **20** is used to fill in the voids created by the use of flipchip contacts. Lens **11** again forms a barrier to heat flow out of the device from both convectively and radiatively. The luminescent converter **14** is typically attached after the flipchip mounted die **15** is mounted and interconnected to substrate **19**. A bonding layer **23** between the flipchip mounted die **15** and luminescent element **14** further thermally isolates the luminescent element **14**. Typically, InGaN power LED UV/Blue chips exhibit efficiencies approaching 60% while White InGaN power LED packages are typically 40%. The loss within the luminescent converter **14** therefore represents a substantial portion of the total losses within the device. In the case of an inorganic/organic matrix luminescent converter of FIG. **1A**, the conversion losses are further localized within the individual phosphor powders due to the low thermal conductivity of the silicone or epoxy matrix. The solid luminescent converter **14** has more lateral spreading due to the higher thermal conductivity of the solid material. Both cases are typically Cerium doped YAG with an intrinsic thermal conductivity of 14 W/m/K. However since the silicone matrix has a thermal conductivity less than 0.1 W/m/K and surrounds substantially all the phosphor powders, the inorganic/organic matrix has a macro thermal conductivity roughly equivalent to the silicone or epoxy by itself. Very high loading levels of phosphor powder can be used but lead to efficiency losses due to higher scatter.

There is simply nowhere for the heat generated in luminescent converter **14** to go except be thermally conducted into the flipchip mounted LED **15** via the bonding layer **23**. In most cases, solid luminescent converters **14** must have an additional leakage coating **22** that deals with blue light that leaks out of the edge of the flipchip mounted LED **15**. An inorganic/organic matrix suffers from the same issues in FIG. **1A**. In both FIGS. **1A** and **1B**, the emission surface are substantially different from the cooling surfaces. The thermal schematic for FIG. **1B** is similar to FIG. **1A** in that heat generated within the luminescent converter **14** is substantially dissipated through the flipchip mounted LED **15**. With the advent of high powered LEDs, a substantially portion of the heat generated

14

within the device can be localized within luminescent converter **14**. This localization has led to a variety of solutions including the use of remote phosphors. In general, luminescent converter **14** efficiency reduces as its average temperature **T4** increases. In the prior art the luminescent converter **14** dissipates the majority of its heat through the flipchip mounted LED **15** with an average temperature of **T5**. This is an inherently higher temperature than the ambient. The need exists for techniques whereby the heat generated within luminescent converter **14** can be reduced for higher efficiency devices.

FIG. **2A** depicts a vertical LED **24** of the present invention in which the optical emission rays **26** travel substantially in the same direction as the thermal rays **27**. A thermally conductive luminescent element **25** provides wavelength conversion for at least a portion of the light emitted by vertical LED **24** and acts as an optical and thermal spreading element, extraction means, and a substrate for the electrical interconnect. In FIG. **2A**, overcoat **30** may be reflective, transparent, partially reflective and exhibit reflectivity which is wavelength and/or polarization dependent.

Wire bond **29** connects interconnect **28** to contact pad **33** with contact **34** attached via conductive ink or eutectic solder to interconnect **31**. A transparent/translucent bonding layer **32** maximizes optical and thermal coupling into thermally conductive luminescent element **25** and eventually out of the device. The transparent/translucent bonding layer **32** may consist of, but is not limited to, glass fit, polysiloxane, polysilazane, silicone, and other transparent/translucent adhesive materials. Transparent/translucent bonding layer **32** has a thermal conductivity greater than 0.1 W/m/K and even more preferably greater than 1 W/m/K. Thermally conductive luminescent element **25** may consist of, but is not limited to, single crystal luminescent materials, polycrystalline luminescent materials, amorphous luminescent materials, thermally conductive transparent/translucent materials such as Sapphire, TPA, Nitrides, Spinel, cubic zirconia, quartz, and glass coated with a thermally conductive luminescent coating, and composites of thermally conductive transparent/translucent material and thermally conductive luminescent materials.

In FIG. **2A** a high emissivity layer **35** may be applied to the thermally conductive luminescent element **25** to enhance radiative cooling. In addition, high emissivity layer **35** may also provide enhanced extraction efficiency by acting as an index matching layer between the surrounding air and the thermally conductive luminescent element **25**, especially in the case where extraction elements are used to increase extraction from the thermally conductive luminescent element **25**. Unlike the previous prior art thermal schematic, the flow of heat generated in the thermally conductive luminescent element **25** is directly coupled to the ambient via convective and radiative cooling off the surface of the thermally conductive luminescent element **25** itself. This direct coupling approach can only be effectively accomplished if the bulk thermal conductivity of the thermally conductive luminescent element **25** is high enough to effectively spread the heat out over an area sufficiently large enough to effectively transfer the heat to the surrounding ambient. As such, a thermally conductive luminescent element has a surface area greater than the attached LED with an average bulk thermal conductivity greater than 1 W/m/K wherein the heat generated within the Vertical LED **24** and thermally conductive luminescent element **25** are substantially transferred to the surrounding ambient via convection and radiation off the surface of thermally conductive luminescent element **25**. High emissivity layer **35** most preferably has an emissivity greater than 0.8 at 100 degrees C. and an absorption less than

0.2 throughout the visible spectrum. Alternately, the emissivity of the thermally conductive luminescent element **25** may be greater than 0.8 at 100 degrees C. and have an absorption less than 0.2 throughout the visible spectrum.

FIG. 2B depicts a flip chip mounted LED **36** mounted on thermally conductive luminescent element **42** via a transparent/translucent bonding layer **43** and electrically connected via contacts **41** and **40** to interconnects **44** and **45** on thermally conductive luminescent element **25**. Interconnects **44** and **45** are thick film silver conductors formed via screen printing, inkjet printing, lithographic means, or combinations of these other methods. As an example, thermally conductive luminescent element **42** may contain a laser cut trench approximately 5 micron deep into which silver paste is screen printed and fired. The surface of conductive luminescent element **42** is then optionally lapped to create a smooth surface for interconnect **44** and **45**. The resulting surface is now smooth enough for thermo compression bonded die, direct die attach die with integral eutectic solders, and other direct attach bonding methods. The interconnects **44** and **45** are typically fired at a temperature greater than 400 degrees C. The interconnects **44** and **45** are thick film or inkjet silver traces with line widths less than or greater than the width of the flip chip mounted LED **36**. Optical losses within the device can be minimized by minimizing the amount of silver used, minimizing the width of the interconnect traces and maximizing the reflectivity of the silver traces. Alternately, the thermal resistance between flip chip mounted LED **36** and the thermally conductive luminescent element **42** may be minimized by increasing amount of silver thickness or area. Overcoat **37** may consist of, but is not limited to, glass frit, polysiloxane, polysilazanes, flame sprayed ceramics, and evaporative/CVD coatings. A highly reflective layer in overcoat **37** is optional. In this manner, a compact directional light source can be formed. Transparent/translucent bonding layer acts as an environmental and shorting barrier for the device. The reflector in overcoat **37** can be applied after all the high temperature processing thereby maximizing reflectivity of the layer. The thermal schematic shown in FIG. 2B again shows that there is a much different thermal conduction path than FIG. 1 devices. Thermally conductive luminescent element **42** provides the cooling surfaces for the device as well as conversion of light from LED **36**. The emitting surface of the device is also the cooling surface of the device.

FIG. 2C depicts a lateral LED **53** mounted onto thermally conductive luminescent element **46**. As in FIG. 2A and FIG. 2B, the optical emission **50** and thermal rays **51** travel in substantially the same direction. In this configuration, a transparent/translucent overcoat **48** couples thermal rays **56** and optical emission **57** out the backside of the device. Optical emission **50** and optical emission **57** maybe the same or different from each other regarding emission spectrum, intensity, or polarization. Additives, coatings, and combinations of both can effect the emission spectrum, intensity and polarization within overcoat **48**. Interconnect **49** and **54** may consist of, but are not limited to, electrically conductive materials in a dielectric matrix. A silver flake thick film paste screen can be printed and fired at greater than 400 degrees C. with a reflectivity greater than 50% to form an electrically conductive material in a dielectric matrix. Wire bond **47** and **52** connect LED contacts **56** and **55** to interconnect **49** and **54** respectively. Gold wire is preferred but the wire bond can be silver, silver coated gold, and aluminum in wire, foil, and tape form. The thermal schematic illustrates the flow of heat through the device to ambient. Transparent/translucent overcoat **48** may also contain luminescent materials. As an example, transparent/translucent overcoat **48** may consist of

inorganic/organic matrix material such as but not limited to HT 1500 Polysilazane (Clariant Inc.) containing at least one luminescent materials such as, but not limited to, Eljen EJ-284 fluorescent dye for conversion of green and yellow emission into red. Luminescent coatings can be applied via dip coating, spraying, inkjet, and other deposition techniques to form transparent/translucent overcoat **48** on a light emitting device containing at least one thermally conductive luminescent element **46**.

FIG. 3A depicts a self cooling light source consisting of a single thermally conductive luminescent element **60** attached both thermally and optically onto at least one LED **61**. LED **61** may consist of InGaN, GaN, AlGaN, AlInGaP, ZnO, AlN, and diamond based light emitting diodes. Both blue and red light emitting diodes such as, but not limited to, InGaN and AlInGaP LEDs are attached optically and thermally to at least one thermally conductive luminescent element **60**. Heat **59** and emission **58** generated by the LED **61** and the thermally conductive luminescent element **60** are spread out over a substantially larger area and volume than the LED **61**. In this manner the heat generated can be effectively transferred to the surrounding ambient.

Ce:YAG in single crystal, polycrystalline, ceramic, and flame sprayed forms are preferred materials choices for thermally conductive luminescent element **60**. Various alloys and dopants may also be used consisting of but not limited to gadolinium, gallium, and terbium. The thermally conductive luminescent element **60** can be single crystal cerium doped YAG grown via EFG with a cerium dopant concentration between 0.02% and 2%, preferably between 0.02% and 0.2% with a thickness greater than 500 microns. Alternatively, the thermally conductive luminescent element **60** can be flame sprayed Ce:YAG with an optional post annealing. The thermally conductive luminescent element **60** can be formed by flame spraying, HVOF, plasma spraying under a controlled atmosphere directly onto the LED **61**. This approach maximizes both thermal and optical coupling between the thermally conductive luminescent element and LED **61** by directly bonding to LED **61** rather than using an intermediary material to bond the LED **61** to thermally conductive luminescent element **60**. Alternately, the thermally conductive luminescent element **60** maybe formed using at least one of the following methods; hot pressing, vacuum sintering, atmospheric sintering, spark plasma sintering, flame spraying, plasma spraying, hot isostatic pressing, cold isostatic pressing, forge sintering, laser fusion, plasma fusion, and other melt based processes. Thermally conductive luminescent element **60** may be single crystal, polycrystalline, amorphous, ceramic, or a melted composite of inorganics. As an example, 100 grams alumina and Ce doped Yag powder which have been mixed together are placed into a container. The powders are melted together using a 2 Kw fiber laser to form a molten ball within the volume of the powder. In this manner the powder acts as the crucible for the molten ball eliminating any contamination from the container walls. The use of the fiber laser allows for formation of the melt in approximately 4 seconds depending on the beam size. While still in a molten state the ball may optionally be forged between SiC platens into a plate. Most preferably the molten ball is greater than 10 mm in diameter to allow sufficient working time as a molten material for secondary processing The plate may be further processed using vacuum sintering, atmospheric sintering, or hot isostatic pressing to form a translucent thermally conductive luminescent element **60**. The use of fiber laser based melt processing is a preferred method for the formation of luminescent oxides, nitrides, and oxynitrides as a method of reducing energy costs compared to hot pressing or vacuum

sintering. The use of controlled atmospheres including vacuum, oxygen, hydrogen, argon, nitrogen, and ammonia during the laser based melting processes is disclosed. While fiber lasers are preferred the use of localized actinic radiation to form a molten mass within a powder mass to form thermally conductive luminescent element **60** is disclosed.

FIG. **3B** depicts a self cooling light source consisting of at least two thermally conductive luminescent elements **62** and **63** attached to at least one LED **64**. In this case, both thermal emission **64** and optical emission **65** can be spread out and extracted from both sides of LED **64**. In all cases, multiple LEDs allow for parallel, series, anti-parallel, and combinations of all three with the appropriate electrical interconnect. In this case, optical emission **65** can be substantially similar or different on the two sides of the devices. As an example, thermally conductive luminescent element **62** can be 1 mm thick single crystal Ce doped YAG formed via EFG bottle which is then sliced into 19 mm×6 mm wafers. The sliced surface enhances extraction of the Ce:YAG emission out of the high index of refraction Ce:YAG material. Alternately, thermally conductive luminescent element **63** may be a pressed and sintered translucent polycrystalline alumina with a thermally fused layer of Mn doped Strontium Thiogallate and a layer of Eu doped Strontium Calcium Sulfide within a glass frit matrix. In this manner, a wide range of optical emission spectrums can be created.

In this particular case, the two sides of the devices will emit slightly different spectrums. In general, unless an opaque reflector is placed between thermally conductive luminescent elements **62** and **63** there will be significant spectral mixing within this device. This configuration can be used for quarter lights, wall washers, chandeliers, and other light fixtures in which a substantial portion of the optical emission **65** is required to occur in two separate directions. Directional elements such as BEF, microoptics, subwavelength elements, and photonic structures impart more or less directionality to the optical emission **65** of either thermal conductive luminescent elements **62** and/or **63**.

In another example, Cerium doped YAG is formed via flame, HVOF, or plasma spraying and then optionally annealed, spark plasma sintered, microwave sintering, or HIP to improve its luminescent properties for one or both thermally conductive luminescent element **62** and/or **63**. At least one InGaN LED and at least one AlInGaP LEDs are used for at least one LED **64**.

In yet another example, high purity aluminum oxide is flamesprayed directly onto at least one LED die **64** for thermally conductive luminescent element **62** forming a translucent reflector. The emissivity of flame sprayed aluminum oxide is typically 0.8 allowing for enhanced radiative cooling from that surface. Thermally conductive luminescent element **63** is single crystal Ce:YAG formed via skull melting and sliced into 0.7 mm thick wafers 0.5 inch×1 inch in area with a cerium doping concentration between 0.1% and 2%. In this case thermally conductive luminescent element **62** does not necessarily contain a luminescent material but acts as diffuse reflector and thermal spreading element for the heat generated by both LED **64** and thermally conductive luminescent element **62**. By embedding LED **64** directly into thermally conductive luminescent element **62** it is possible to eliminate pick and place, die attachment processes and materials, and maximize both thermal transfer **64** and optical emission **65** by eliminating unnecessary interfaces. Additional luminescent materials and opaque reflectors can be positioned within or coating onto either thermally conductive luminescent elements **62** or **63**. Pockets or embedded die can recess the die

such that printing techniques including but not limited to inkjet, silkscreen printing, syringe dispensing, and lithographic means.

FIG. **3C** depicts two thermally conductive luminescent elements **72** and **74** providing thermal conduction paths **74** and **79** to additional cooling means **71** and **73**. In this case, thermally conductive luminescent elements **72** and **74** allow for thermal emission **76** and optical emission **77** and also provide for thermal conduction paths **74** and **79**. Additional cooling means **71** and **73** may also provide for electrical connection to LED **75** via interconnect means previously disclosed in FIG. **2**. One or more additional cooling means **71** and **73** further enhance the amount of heat that can be dissipated by the device. As an example, a typical natural convection coefficient is 20 W/m²/K and CeYag has an emissivity of 0.8 near room temperature. A self cooling light source consisting of two ¼ inch×½ inch×1 mm thick pieces of CeYag **72** and **74** with four direct attach LEDs **75** soldered on silver thick film interconnect traces has a surface area of approximately 2.3 cm². Using natural convection and radiative cooling approximately 500 milliwatts of heat can be dissipated off the surface of the self cooling light source if the surface temperature is approximately 100 degrees C. and the ambient is 25 degrees C. and the emissivity is 0.8. Of the 500 milliwatts, 350 milliwatts of heat is dissipated via natural convection cooling and 150 milliwatts are dissipated via radiation. A typical 4000K spectrum output has an optical efficiency of 300 lumens per optical watt. If the solid state light source has a electrical to optical conversion efficiency of 50%, 500 milliwatts of optical output is generated for every 500 milliwatts of heat generated. Under these conditions a ¼ inch×½ inch solid state light source operating with a surface temperature of approximately 100 degrees C. can output **150** lumens without the need for additional heatsinking means. The use of additional cooling means **71** and **73** can be used to significantly increase this output level by increase the surface area that heat can be convectively and radiatively transferred to the ambient. As is easily seen in the example, increasing the surface area is directly proportional to amount of heat that can be dissipated. It is also clear that the electrical to optical conversion efficiency dramatically effects the amount of heat generated which a key attribute of this invention. Unlike conventional LED packages light generated within this self cooling solid state light source is extracted out of both sides of the device. Isotropic extraction as shown has a 20% theoretical higher efficiency than lambertian extraction. Also using this approach, the temperature difference between the LED **75** junction and the surfaces of thermally conductive luminescent elements **72** and **74** can be very low if the thermal conductivity is greater than 10 W/m/K and the LEDs **75** are attached such that there is low thermal resistance to the surrounding thermally conductive luminescent elements **72** and **74**. In addition, cooling means **71** and **73** may be physically different to allow for the device to connect to different external power sources correctly. As an example, cooling mean **71** may be a pin and cooling means **73** maybe a socket such that a keyed electrical interconnect is formed. Alternately, cooling means **71** and **73** may contain magnets which allow for attachment of external power sources. Even more preferably the magnets have different polarity such that a keyed interconnect can be formed. Additional cooling means **71** and **73** may include, but are not limited to, heatpipes, metals, glass, ceramics, boron nitride fibers, carbon fibers, pyrolytic graphite films, and thermally conductive composites. As an example, boron nitride nano tubes fibers, as provided by BNNT Inc., are pressed with exfoliated boron nitride flakes to form and thermally interconnected skeleton matrix using

pressing, cold isostatic pressing, warm isostatic pressing, and/or hot isostatic pressing to form a solid sheet. The boron nitride nanotube fibers interconnect the boron nitride flakes and bond to the surface of the boron nitride flakes such that a continuous thermal matrix is formed. The resultant skeleton matrix may then be infused with polymeric or polymeric ceramic precursors including but not limited to polysilazane, polysiloxane, glasses, silicones, and other polymeric materials to form a composite. Alternatively, The boron nitride nanotube fibers may be foamed into a yarn and woven into a cloth or felt and then infused with to form a thermally conductive composite. Alternately, high thermal conductivity carbon fibers and films may be used but boron nitride is preferred due to its low optical absorption compared to carbon based approaches. Alternately, carbon based additional cooling means **71** and **73** may include a reflective layer to reduced absorption losses and redirect light from the source as well as provide additional cooling. Additional cooling means **71** and **73** may also diffuse, reflect, or absorb optical emission **77** emitting between or from the adjacent edge of thermally conductive luminescent element **72** or **74**. In this manner the far field emission of the device can be adjusted both from an intensity and spectral standpoint. Doubling the surface cooling area using additional cooling means **71** and **73** approximately doubles the lumen output as long as the thermal resistance of the additional cooling means **71** and **73** is low.

FIG. 4A depicts at least one LED **85** embedded within thermally conductive luminescent element **83**. Thermally conductive luminescent element **83** may be formed via press sintering of aluminum oxide as known in the art to form a translucent polycrystalline alumina TPA with depressions sufficiently deep enough to allow for LED **85** to be recessed. Luminescent coating **84** may be substantially only in the pocket formed in thermally conductive luminescent element **83** or may cover substantially all the surfaces of thermally conductive luminescent element **83**. Alternately, single crystal, polycrystalline or amorphous phosphor, pieces, plates, rods and particles can be fused or bonded into or onto thermally conductive luminescent element **83**. In this manner, the quantity of luminescent material can be minimized while maintaining high thermal conductivity for the thermally conductive luminescent element **81**.

As an example, single crystal Ce:YAG pieces 1 mm×1 mm and 300 microns thick can be fusion bonded into 1.1 mm×1.1 mm×500 micron deep pockets formed into TPA press sintered plates and then fired at 1700 degrees C. in a vacuum for 10 hours such that the single crystal YAG pieces are optical and thermally fused into the bottom of the TPA pockets. LED **85** can then be bonded into the remaining depth of pocket and be used to excite the single crystal Ce:YAG pieces locally. The combined optical emission from LED **85** and the single crystal Ce:YAG pieces would be spread out and extracted by the sinter pressed TPA while still maintaining high thermal conductivity.

Alternately, luminescent powders in glass frits, polysiloxane, polysilazane, and other transparent binders can form luminescent coating **84**. In particular, high temperature binders in luminescent coating **84** such as polysilazane with luminescent powders, flakes, rods, fibers and in combination both pre-cured and as a bonding agent can be positioned between thermally conductive luminescent element **83** and at least one LED **85**.

Materials with high visible spectrum transmission, lower refractive index, high thermal conductivity, and low processing costs for net and final shape are preferred materials for thermally conductive luminescent element **83**. These materials include, but are not limited to, TPA, Spinel, Quartz, Glass,

ZnS, ZnSe, ZnO, MgO, AlON, ALN, BN, Diamond, and Cubic Zirconia. In particular, Spinel and TPA formed via press sintering are low cost of manufacture of net shape parts. The use of techniques used to form TPA parts as seen in transparent dental braces as known in the art with luminescent elements either as coatings or bonded elements can create thermally conductive luminescent element **83**.

With LED **85** recessed into thermally conductive luminescent element **83**, printing and lithographic methods can be used to electrically interconnect at least one LED **83** to outside power sources and/or other LEDs or devices. Unlike wirebonding, this approach creates a low profile method of interconnecting LEDs which eases assembly of multiple sticks and reduces costs.

In one example, LED **85** is bonded into a pocket formed via laser ablation in a 1 mm thick wafer of Spinel to form thermally conductive luminescent element **83**. In this example the Spinel may or may not include luminescent elements or properties. The majority of the wavelength conversion instead occurs locally around LED **85** via luminescent coating **84** and/or additional luminescent coating **82**. This minimizes the amount of luminescent material necessary yet still allows for a low thermal resistance to ambient for the luminescent materials. While only a single side is shown in FIG. 4, the light source may also be bonded to another light source, heatsink, another transparent/translucent thermally conductive element to further enhance cooling and optical distribution from LED **85** and any luminescent elements within the light source. LED **85** is bonded into the pocket using polysilazane containing 0.1% to 2% doped Ce:YAG powder with a particle size below 10 microns.

Transparent/translucent dielectric layer **81** is inkjet printed over at least one LED **85** except contact pads **87** and **86**. In the case where LED **85** uses TCO based contacts, at least a portion of the TCO is not covered by transparent/translucent dielectric **81** to allow for electrical contact. Optionally an additional luminescent coating **82** may be printed or formed on at least one LED **85** to allow for additional wavelength conversion and to create a more uniform spectral distribution from the device. Interconnects **80** and **88** may then be applied either before or after curing of transparent/translucent dielectric **81**. Polysilazane, polysiloxane, glass frit, spin-on glasses, and organic coatings are examples of transparent/translucent dielectric **81**, preferably the coatings can maintain transparency above 300 degrees C. Formulations containing Polysilazane with and without luminescent elements are preferred materials for additional luminescent coating **82**, transparent/translucent dielectric **82** and luminescent coating **84**. Preferred luminescent elements are powder phosphors, quantum dots, fluorescent dyes (example wavelength shifting dyes from Eljen Technologies) and luminescent flakes and fibers.

Electrical connection to LED **85** is via interconnects **80** and **88** for lateral LED designs. Precision inkjet printing of silver conductive inks and/or screen printing of thick film silver inks form interconnects **80** and **88**. As an example thick film silver paste is screen printed and fired onto thermally conductive luminescent element **83** up to the pocket for LED **85**. Transparent/translucent dielectric **81** is inkjet printed such that only contacts **87** and **86** are left exposed and the transparent/translucent dielectric **81** covers the rest of the exposed surface of LED **85** and at least a portion of thermally conductive luminescent element **83** in a manner to prevent shorting out LED **85** but still allowing access to the thick film silver paste conductors applied earlier. After or before curing of transparent/translucent dielectric **81** and optionally additional luminescent coating **82**, conductive ink is inkjet printed connecting the thick film silver conductor applied previously to the

contacts **86** and **87**. Using this approach, alignment issues can be overcome due to the availability of inkjet systems with image recognition and alignment features while still allowing for low resistance conductors. In general, while inkjet printing of conductors can be very accurate and be printed with line widths under 50 microns, the thickness is typically limited to under 10 microns which limits the current carry capacity of long lines. Using this approach, thick film silver conductors which can be over 50 microns thick can be used to carry the majority of the current and then short inkjet printed traces can be used to stitch connect between the thick film silver conductors and contacts **87** and **86**. Using this approach, gold wire bonding can be eliminated.

A transparent/translucent overcoat **89** may be applied over at least a portion of interconnects **80** and **89** and/or transparent/translucent dielectric **81**, additional luminescent coating **82**, and thermally conductive luminescent element **83** to environmentally and/or electrically isolate the device. Protective barrier layers on LED die **85** can be formed during LED fabrication to facilitate or even eliminate the need for transparent/translucent dielectric layer **81** and allow for direct printing of interconnect **89** and **88** onto contacts **87** and **86** respectively. Catalytic inks and/or immersion plating techniques allow for the formation of thicker/lower resistivity traces for interconnect **89** and **88**, eliminate the need for thick film printing and allow for the use of inkjet printing for the entire interconnect. Preferred materials for transparent/translucent overcoat **89** include but are not limited to polysilazane, polysiloxane, spin-on glasses, organics, glass frits, and flame, plasma, HVOF coatings. Planarization techniques based on spin-on glasses and/or CMP can be used for transparent/translucent overcoat **89**. Luminescent elements including but not limited to powders, flakes, fibers, and quantum dots can be incorporated in transparent/translucent overcoat **89**, transparent/translucent dielectric **81**, and additional luminescent coating **82**. Luminescent elements may be spatially or uniformly dispersed in these layers.

FIG. 4B depicts a light source in which a luminescent layer **91** is formed on a transparent/translucent element **90** containing extraction elements. Transparent/translucent element **90** can be, but is not limited to, single crystalline materials such as sapphire, cubic zirconia, YAG (doped and undoped), ZnO, TAG (doped and undoped), quartz, GGG (doped and undoped), GaN (doped and undoped), AlN, oxynitrides (doped and undoped), orthosilicates (doped and undoped), ZnS (doped and undoped), ZnSe (doped and undoped), and YAGG (doped and undoped), polycrystalline materials, and amorphous materials such as glass, ceramic YAG (doped and undoped), ALON, Spinel, and TPA. In general, single crystal materials grown via verneuil, EFG, HEM, Czochralski, CVD, hydrothermal, skull, and epitaxial means can be the transparent/translucent element **90**.

Luminescent layer **91** may be formed directly on transparent/translucent element **90** or be formed separately and then bonded to transparent/translucent element **90**. Flame-spraying, plasma spraying, and HVOF techniques can form either or both luminescent layer **91** and transparent/translucent element **90**. The light source can have a transparent/translucent element **90** with an alpha less than 10 cm⁻¹ throughout the visible spectrum and a luminescent layer **91** containing at least one luminescent element emitting between 400 nm and 1200 nm. The luminescent layer **91** can exhibit a refractive index which is not more than 0.2 different than transparent/translucent element **90**. LED **99** may be InGaN, AlInGaP, ZnO, BN, Diamond, or combinations of InGaN, AlInGaP, ZnO, BN, or diamond.

Both InGaN and AlInGaP LEDs can be used for LED **99** combined with a transparent/translucent element **90** consisting of at least one of the following materials; sapphire, spinel, quartz, cubic zirconia, ALON, YAG, GGG, TPA, or ZnO and luminescent layer **91** and/or additional luminescent layer **98** containing Ce doped YAG. An additional red phosphor emitting between 585 and 680 nm can be used within luminescent layer **91** and/or additional luminescent layer **98**. These elements form a self cooling light source which emits an average color temperature between 6500K and 1200K that lies substantially on the black body curve is a preferred embodiment of this invention. The self cooling light source can emit an average color temperature between 4000K and 2000K than lies substantially on the blackbody curve.

Multiple self cooling light sources can be used within a fixture, reflector, optic or luminaire such that color and intensity variations are averaged out in the far field. Three or more self cooling light sources within a fixture, reflector, optic or luminaire creates a uniform illumination at a distance greater than 6 inches from the sources. Transparent/translucent dielectric layer **93** may be inkjet printed, silk screen printed, formed via lithographic means and exhibits an alpha less than 10 cm⁻¹ throughout the visible spectrum. Interconnect **95** and **94** may be printed using inkjet, silkscreen, template, or lithographic means. Catalytic inks and immersion plating techniques increase conductor thickness and thereby reduce resistivity. Silver traces with a trace width less than 500 microns and a reflectivity greater than 50% for interconnect **95** and **94** reduce absorption of the light generated within the light source. Contacts **96** and **97** on LED **99** may be on one side only as in lateral devices or consist of one top contact and one side contact as previously disclosed in US Patent Application 20060284190, commonly assigned and herein incorporated by reference.

FIG. 4C depicts a self-cooling light source with at least one vertical LED **100** mounted to or at least partially embedded in thermally conductive luminescent element **103**. Composite, layer, single crystal, polycrystalline, amorphous, and combinations as described previously can be used for the thermally conductive luminescent element **103**. In this particular example, one vertical LED **100** is mounted such that interconnect **101** and **102** may be printed via inkjet, silkscreening, or lithographic means directly on thermally conductive luminescent element **103** and in contact with a side of vertical LED **100**. This embodiment eliminates the need for an additional dielectric and allows for the use of vertical LED devices which inherently exhibit lower Vf than lateral devices. A substrate free LED as described in US patent application 20090140279 (commonly assigned and incorporated herein by reference) is a preferred embodiment for LED **100**. Direct die attach and flip chip mounting configurations may also be used for LED **100**. For the substrate free case, InGaN and/or AlInGaP vertical LED **100** has TCO contacts **104** and **105** for LED **100** wherein the interconnects **101** and **102** are thick film silver inks which form ohmic contact to the adjacent TCO contact **104** and **105**. In this manner, absorption losses are minimized and the need for lithographic steps to fabricate LED **100** is eliminated or minimized. A self cooling light source contains at least one vertical LED **100** with TCO contacts **104** and **105** connected via thick film silver traces for interconnect **101** and **102** directly bonded to TCO contacts **104** and **105** on a thermally conductive luminescent element **103**. Optionally, bonding layer **106** may be used to mount, improve extraction, incorporate additional luminescent materials or position LED **100** onto or within thermally conductive luminescent element **103**.

FIG. 5 depicts various shapes of thermally conductive luminescent elements. FIG. 5A depicts a substantially flat luminescent element **107**. Thickness is a function of dopant concentration but typically the thickness ranges from 200 micron to 2 mm for a uniformly doped Ce doped YAG with a Cerium doping concentration between 0.02% and 10%. In order for efficient thermal spreading to occur, the thermal conductivity of the thermally conductive luminescent element **107** needs to be greater than 1 W/m/K to adequately handle average power densities greater than 0.1 W/cm² of surface area on luminescent element **107**. If the thermal conductivity is too low there is insufficient thermal spreading of the heat generated within the device which decreases the ability of the flat luminescent element **107** to cool itself via natural convection and radiative means.

FIG. 5B depicts a non-flat (hemispheric) luminescent element **108**. In this case, light extraction can be enhanced for those rays which are waveguiding within the higher refractive index of non-flat luminescent element **108**. In addition, far field intensity and wavelength distributions can be modified. Multiple smaller self cooling light sources with the same or different shaped thermally conductive luminescent elements create uniform or specific far field intensity and wavelength distributions. The extraction of light generated within a medium with a refractive index greater than air is restricted by total internal reflection per Snell's Law. Shaped luminescent elements **108** can be used to reduce the average optical path length of optical rays required to escape the luminescent element **108**. Since absorption losses are directly proportional to the optical path length for a given absorption coefficient (α), reducing the average optical path length directly translates into reduced absorption losses. The spatial location of where the optical rays are generated within luminescent element **108**, the refractive index of luminescent element **108**, absorption coefficient (α) of luminescent element **108**, bulk and surface scattering within and on luminescent element **108**, and the geometry of luminescent element **108** can all be modeled as known in the art to optimize the extraction efficiency.

FIG. 5C depicts a non-flat (curved) thermally conductive luminescent element **109** with a substantially uniform thickness. In this manner extraction can be enhanced by maintaining a uniform thickness of luminescent material. Extrusion, pressing, molding, sawing, boring, and flame spraying techniques as known in the art may be used to fabricate various shapes of thermally conductive luminescent elements.

FIG. 5D depicts a non-flat (rectangular saw tooth) thermally conductive luminescent element **110** with additional surface elements to enhance convection cooling and optionally to modify or homogenize the emission output of the self-cooling light source. Extrusion, pressing, and molding techniques may be used to form thermally conductive luminescent element **110**.

FIG. 6A depicts a partially embedded LED **108** within a depression in thermally conductive luminescent element **107** mounted via bonding layer **109**. The formation of the depression may be by laser machining, ebeam machining, etching (both chemical and mechanical), plasma etching, molding, and machining means. Substrate-free LEDs may be used for partially embedded LED **108** with a thickness less than 300 microns. By embedding partially embedded LED **108** in thermally conductive wavelength conversion element **107**, the thermal resistance between the two elements can be reduced which lowers the junction temperature of the LED for a given drive level. Optionally, more of the emission from partially embedded LED into thermally conductive luminescent ele-

ment **107** can be coupled thereby changing the color temperature of the self cooling light source.

FIG. 6B depicts at least one LED **112** bonded onto thermally conductive luminescent element **110** via bonding layer **111**. In this case, bonding layer **111** should exhibit a thermal conductivity greater than 1 W/m/K and an α less than 10 cm⁻¹ for the emission wavelengths of LED **112**.

FIG. 7 depicts various printed contacts for TCO contact based LEDs. FIG. 7A depicts a vertical LED consisting of a top silver paste contact **113** on TCO layer **114** on p layer **117**. Active region **116** is between p layer **117** and n layer **115** with n layer **115** covered with TCO contact **118** and bottom silver paste contact **119**. A substrate free LED allows dual sided growth of TCO contact layers **114** and **118** on substrate free LED structures consisting of p layer **117**, active layer **116** and n layer **115**. Thick film high temperature silver paste contacts **113** and **119** can be printed on LEDs with TCO contacts **114** and **118** and fired at temperatures greater than 200 degrees C. in various atmospheres to form a low optical absorption, low Vf, and substantially lithography free LED devices.

FIG. 7B depicts a lateral device with printed/inkjet printed contacts **120** and **125**. In all cases, ohmic contact to the n layer may include or not include an intermediary TCO layer to form reasonable ohmic contact. In FIG. 7B, TCO **122** is grown on p layer **123**. Active layer **124** is between p layer **123** and n layer **125**. TCO **122** is doped ZnO grown via CVD with a resistivity less than 0.003 ohm-cm and greater than 1000 Angstroms thick. Printed etch masks allow for etch of the step down to n layer **125**. As an example, an AlInGaP LED epi may be grown on GaAs. The wafer can be etched and patterned to form the lateral device having TCO **122** on the p layer **123**. Printed contacts **120** and **125** are formed on TCO **122** and n layer **125**. Optionally an additional TCO layer maybe formed of n layer **125** to further reduce Vf. The addition of a eutectic solder layer to printed contact **120** and **125** to create a direct die attach die is also disclosed. In a preferred embodiment, the AlInGaP epi is removed via chemical etching using a sacrificial etching layer between the AlInGaP and GaAs substrate as known in the art. The resulting direct attach die may be additionally wafer bonded to GaN substrates as disclosed in U.S. Pat. Nos. 7,592,637, 7,727,790, 8,017,415, 8,158,983, and 8,163,582, and US Patent Applications Publication Nos. 20090140279 and 20100038656, commonly assigned as the present application and herein incorporated by reference.

FIG. 7C depicts a printed contact with a top contact **126** and side contacts **132** and **130**. Again TCO **127** forms a low ohmic transparent ohmic contact to p layer **128** and the active region **129** is between p layer **128** and n layer **130**. Side contacts **131** and **132** contact the side walls of n layer **130**. N layer **130** is greater than 10 microns of thickness. Even more preferably, the thickness of n layer **130** is greater than 50 microns but less than 250 microns.

FIG. 8 depicts various methods of changing the far field distribution of single self cooling source. In FIG. 8A, the refractive indices, geometry, and spacing of the LEDs **136**, the wavelength conversion elements **133** and **135**, and the bonding material **137** will determine the far field distribution of the source. The far field distribution is determined by where the optical rays exit, how much of the optical rays, the direction of the optical rays and the spectrum of optical rays that exit a particular spatial point on the single self cooling source. FIG. 8 illustrates various reflectors, scattering elements, and diffusers which modify where, how much, which way and the spectrum of the light rays emitted from the source. One or more wavelength conversion elements for mounting LEDs **136** can be used although two wavelength conversion elements **133** and **135** are depicted. Multiple

LEDs **136** can be mounted on one or more surface of the one wavelength conversion element **133**. Based on these parameters, radiation will be emitted from the structure or light guided within the source. Additionally, edge element **134** may also modify the far field distribution out of the device. Edge element **134** and bonding materials **137** may be translucent, transparent, opaque, and/or luminescent. Luminescent powders within a transparent matrix for edge element **134** and bonding materials **137** can modify the emission spectrum as well as the far field intensity distribution.

FIG. **8B** depicts a self cooling light source where the entire end of the self cooling light source is substantially covered with a scattering element **139** within a matrix **138**. Additionally, scattering element **139** and matrix **138** may extend to encompass not only edges of the self cooling light source but also a substantial portions of the other surfaces of the self cooling light source. In this manner, light emitted from all the surface of the self cooling light source can be redirected to modify the far field intensity distribution. Luminescent materials for scattering element **139** are excited by at least a portion of the spectrum emitted by the self cooling light source.

FIG. **8C** depicts edge turning element **140** consisting of metal, diffuse scatterer, dielectric mirror, and/or translucent material whereby at least a portion of the light generated within the LED or wavelength conversion elements are redirected as depicted in ray **141**.

FIG. **8D** depicts an outer coating **142** which may be translucent, partially opaque, polarized, and/or luminescent. The far field intensity, polarization, and wavelength distribution can be modified both in the near field and far field and spatial information can be imparted onto the self cooling light source. As an example, a self cooling light source with a shape similar to a candle flame may have a spectrally variable outer coating **142** such that red wavelengths are emitted more readily near the tip of the candle flame and blue wavelengths are emitted more readily near the base of the candle flame. In this fashion, the spatially spectral characteristics of a candle flame could be more closely matched. Using this technique a wide range of decorative light sources can be formed without the need for additional optical elements.

In another example, outer coating **142** may consist of a reflective coating such as aluminum into which openings are etched or mechanically formed. More specifically, sunlight readable indicator lights can be formed using this technique as warning, emergency, or cautionary indicators. The use of circular polarizers within outer coating **142** can enhance sunlight readability. Alternately, outer coating **142** could be patterned to depict a pedestrian crossing symbol that could be either direct viewed or viewed through an external optic thereby creating a ultra compact warning sign for crosswalks and other traffic related applications. In another example, outer coating **142** may consist of spectrally selective emissivity coating such that the emissivity of the self cooling light source is enhanced for wavelengths longer than 700 nm. By enhancing the infrared and far infrared emissivity of the self cooling light source more efficient light sources can be realized. As stated in the previous example of FIG. **3** the radiation cooling represents a significant percentage of the cooling in self cooling light sources. It is preferred that high emissivity coatings be used for outer coating **142** to maximize cooling from the surface of the self cooling light source. Most preferred is an outer coating **142** with an emissivity greater than 0.5. Depending on the maximum surface temperature the radiative cooling can represent between 20% and 50% of the heat dissipation of the source.

FIG. **9A** depicts the use of die shaping of optical devices within a media **143**. As an example, LED **145** contains an active region **146** embedded within media **143**. Using ray tracing techniques known in the art, there is an optimum angle **144** to maximize the amount of radiation transferred into media **143**. Typically, semiconductor materials exhibit high refractive index which tends to lead to light trapping within the LED **145**. In FIG. **9A** the optimum angle **144** subtends the active region **146** as shown in the figure.

Alternately, FIG. **9B** depicts that surfaces **149**, **148** and **147** may be non-orthogonal forming a non square or rectangular die. In both these cases, light trapped within the LED **150** can more efficiently escape the die. The use of both forms of die shaping together is preferred. The use of non-rectangular shapes for LED **150** embedded within a wavelength conversion element to enhance extraction efficiency is a preferred embodiment of this invention.

FIG. **10A** depicts different mounting methods for LEDs **152** and **154** within wavelength conversion element **151** and the use of bonding layers **153** and **155**. Bonding layers **153** and **155** thermally, optically, and mechanically attach LEDs **152** and **154** to at least one surface of wavelength conversion element **151**. LED **152** is at least partially embedded within wavelength conversion element **151** which can allow for both edge and surface coupling of radiation emitted by the LED **152** into wavelength conversion element **151** using bonding layer **153**. Alternately, LED **154** is substantially coupled to the surface of wavelength conversion element **151** using bonding layer **155**. Bonding layers **153** and **155** may be eliminated where wavelength conversion element **151** is directly bondable to LEDs **154** and **152** using wafer bonding, fusion bonding, or melt bonding.

FIG. **10B** depicts a typical transmission spectrum **157** of wavelength conversion elements. Blue emission **156** is absorbed by the wavelength conversion element and then reemitted at longer wavelengths. Red emission **158** is typically not strongly absorbed and therefore behaves as if the wavelength conversion element **151** is simply a waveguide. Virtually any color light source can be realized by properly selecting the right combination of blue and red LEDs within the wavelength conversion element **151**. While wavelength conversion is a preferred embodiment, FIG. **10B** illustrates that self-cooling light sources do not require that the wavelength conversion element **151** be luminescent. In the case of a red self-cooling light source, wavelength conversion element **151** may be used to optically distribute and thermally cool the LEDs without wavelength conversion. Alternately, UV responsive luminescent materials can be used for wavelength conversion element **162** with UV LEDs **164** or **165**. The transmission spectrum **157** is shifted to shorter wavelength which allows for the formation of self cooling light sources which exhibit white body colors, as seen in fluorescent light sources. This wavelength shift however is offset by somewhat reduced efficiency due to larger stokes shift losses.

FIG. **11** depicts a color tunable self-cooling light source containing at least one wavelength conversion element **162** with an electrical interconnect **168**, at least one blue LED **164**, at least one red LED **163**, and drive electronics **165**, **166**, and **167**. Electrical interconnect **168** is a thick film printed silver ink. Three separate pins **159**, **160**, and **161** to provide independent control of blue led **164** from red LED **163**. Pins **159**, **160**, and **161** can be physically shaped to allow for keying thereby ensuring that the self-cooling light source is properly connected to external power sources. While pins **159**, **160** and **161** are substantially shown on the same side of wavelength conversion element **162**, the use of alternate pin configurations are anticipated by the inventors. In general, external

electrical interconnect can be accomplished via pins **159**, **160**, and **161** as shown in FIG. **11** or via alternate interconnect means including, but not limited to, flex circuits, rigid elements containing electrical traces, coaxial wires, shielded and unshielded twisted pairs, and edge type connectors on or connected to wavelength conversion element **162** are embodiments of this invention. Additionally feedthroughs within wavelength conversion element **162** can be formed via mechanical, chemical etching, laser, waterjet, or other subtractive means to form external interconnects to any of the previous listed electrical interconnect elements in any plane of the wavelength conversion element **162**. Drive electronics **165**, **166**, and **167** may consist of both active and passive elements ranging from resistors, caps, and inductors. In this manner, a variety of external drive inputs can be used to excite the light source. As an example, a current source chip may be mounted onto the wavelength conversion element **162** and connected to an external voltage source via pins **159**, **160**, and **161**. As known in the art, typical current source chips can also have an external resistor which sets the current which flows through the current source chip. The external resistor may be mounted on the wavelength conversion element **162** or be external to the source and connected to current source chip via pins **159**, **160**, and **161**. As the functionality within the light source increases, the number pins may be increased. Integrated circuits can be used for drive electronics **165**, **166**, and/or **167**. Wavelength conversion element **162** also substantially cools the drive electronics **165**, **166**, and **167** as well as LEDs **164** and **165**. Pins **159**, **160**, and **161** may be used to remove heat from the heat generating elements of the light source. Wavelength conversion element **162** is luminescent and provides for optical diffusion and cooling of the heat generating elements within the self cooling light source. In this case, additional wavelength emitters may be added including, but not limited to, UV, violet, cyan, green, yellow, orange, deep red, and infrared.

FIG. **12** depicts a self cooling light source with an embedded active driver **172** capable of driving multiple LEDs **171**, all of which are mounted and cooled substantially by wavelength conversion element **169**. Input pins **170** may provide power input to active driver **172** but also provide outputs including, but not limited to, light source temperature, ambient temperature, light output levels, motion detection, infrared communication links, and dimming controls. As previously disclosed, the transmission spectrum of the wavelength conversion element **169** allows for low absorption of longer wavelengths. An infrared/wireless emitter and receiver can be integrated into embedded active driver **172** so that the self cooling light source could also serve as a communication link for computers, TVs, wireless devices within a room, building, or outside. This integration eliminates the need for additional wiring and devices.

FIG. **13A** depicts the use of electrical contacts **174** and **175** as additional thermal conduction paths for extracting heat **178** out of the wavelength conversion elements **173** and **174** additionally cooling paths for LED **177**. LED **177** may be direct attach or flip chip and may be a lateral, vertical, or edge contact die. As an example, electrical contact **174** and **175** may consist of 0.3 mm thick Tin plated aluminum plates sandwiched between wavelength conversion elements **173** and **174**. In this manner both electrical input and additional cooling means for wavelength conversion elements **173** and **174** as well as LED **177** can be realized.

FIG. **13B** depicts a rod based light source with LEDs **180** within rod shaped wavelength conversion element **182** wherein heat **181** is additionally extracted via conduction to contacts **178** and **179**. Alternately, hemispherical, pyramidal,

and other non-flat shapes and cross-sections may be used for wavelength conversion element **182** to create a desired intensity, polarization, and wavelength distribution. Cross-section and other shapes, such as spheres and pyramids, maximize the surface area to volume ratio, so that convective and radiative cooling off the surface of the wavelength conversion element **182** is maximized while using the least amount of material possible. As an example, contacts **178** and **179** may consist of 2 mm copper heatpipes thermally bonded via a bonding method including but not limited to gluing, mechanical, soldering, or brazing means to wavelength conversion element **182**. In this manner additional cooling may be realized. LEDs **180** may be mounted on the surface or inside of wavelength conversion element **182**. As an example LEDs **180** may be mounted on the flat surface of two hemispherical wavelength conversion elements **182**. The two hemispherical wavelength conversion elements **182** are bonded together to form a spherical self cooling light source with the LEDs **180** embedded within the wavelength conversion elements **182**. Alternately, the LEDs **180** may be mounted on the spherical surface of the hemispherical wavelength conversion element **182** such the light generated by LED **180** generally is coupled into the hemispherical wavelength conversion element **182**. Optionally, the flat surface of hemispherical wavelength conversion **182** may have additional luminescent coatings such that the light emitted by LEDs **180** is effectively coupled by the hemispherical wavelength conversion element **182** onto the luminescent bonding layer which reflects, transmits, converts or otherwise emits both the light emitted by the LEDs **180** and any luminescent elements back out of the hemispherical wavelength conversion element **182**. The advantage of this approach is that the LEDs **180** are mounted closer to the cooling surface of the wavelength conversion element, a high degree of mixing is possible, and the angular distribution of the source can be controlled by how well the bonding layer is index matched to the wavelength conversion element **182**. Bonding two hemispherical wavelength conversion elements **182** together forms a spherical source with externally mounted LEDs **180**.

FIG. **14** depicts a self cooling light source with at least two thermally and/or optically separated zones. Waveguide **183** containing LEDs **184** is optically and/or thermally isolated via barrier **185** from waveguide **186** and LEDs **187**. Dual colored light sources can be formed. Alternately, temperature sensitive LEDs such as AlInGaP can be thermally isolated from more temperature stable InGaN LEDs. Waveguide **183** and **186** may or may not provide luminescent conversion. LED **184** are AlInGaP (red) LEDs mounted to waveguide **183** made out of sapphire. LEDs **187** are InGaN blue LEDs mounted onto waveguide **186** which is single crystal Ce:YAG. The barrier **185** is a low thermal conductivity alumina casting material. AlInGaP efficiency drops by 40% for junction temperatures over 60 degrees C. while InGaN efficiency will drop only by 10% for a similar junction temperature. White light sources can be realized by thermally isolating the AlInGaP from the InGaN high overall efficiency. Using this approach the two sections operate at different surface temperatures. The InGaN LED **187** and waveguide **186** operates at a higher surface temperature while the AlInGaP LED **184** and waveguide **183** operates at a lower surface temperature.

FIG. **15** depicts Blue LED **189** mounted to wavelength conversion element **188** and Red LED **192** with driver **190**. Power lines **191**, **193**, **194**, and **195** and control line **196** are also shown. Red LED **192** drive level is set via control line **196** by controlling the voltage/current flow available via power line input **191** and output **195**. Typically driver **190**

would be a constant current source or variable resistor controlled via control line **196**. As stated earlier, blue LED **189** is typically InGaN with more stable regarding temperature, life and drive levels than red LED **192** typically AlInGaP. As an example, TPA coated with europium doped strontium thiogallate singularly or as a multiphase with another gallate, such as Eu doped magnesium gallate, e for wavelength conversion element **188** is excited by 450 nm LED **189**. 615 nm AlInGaP red LED **192** is also mounted on the wavelength conversion element **188** along with driver **190**. Heat is spread out via wavelength conversion element **188** as well as the radiation emitted by blue LED **189** and red LED **192**. Control line **196** is used to adjust the color temperature of the source within a range by increasing the current to red LED **192** relative to the fixed output of blue LED **189**. Additional LEDs and other emission wavelengths can be used.

FIG. **16** depicts a white light spectrum for a typical solid state light source. FIG. **16A** illustrates high color temperature low CRI spectrum **197** typically created by blue LEDs and Ce:YAG phosphors. Additional phosphors are typically added to add more red content in order to lower the color temperature as shown in spectrum **198**. This red addition however requires that a portion of the blue and in some cases some of the green be absorbed which reduces overall efficiency.

FIG. **16B** depicts the typical spectrum **199** from a blue LED, Ce:YAG phosphor, and red LED. The red LED spectrum is additive as shown in spectrum **200**. In general, both methods of FIG. **16** are used to form self-cooling light source described in this invention.

FIG. **17** depicts a high CRI white light spectrum **201** formed by mixing phosphor and LED spectrums A, B, C, D, and E. Spectral ranges can be mixed, diffused and converted within the wavelength conversion elements disclosed in this invention in addition to cooling, mechanically mounting, environmentally protecting, and electrically interconnecting the devices needed to generate the spectrums depicted. As an example, spectrum B may be derived from a blue 440 nm emitting LED, a portion whose output is used to excite a single crystal CeYAG luminescent element as previously disclosed to form spectrum A between 500 nm and 600 nm. Spectrum C may consist of a cyan quantum dot which also converts a portion of output of the blue 440 nm emitting LED into 490 to 500 nm wavelengths. Spectrum D maybe produced by using a wavelength shifter die such as Eljen-284 (Eljen Technologies Inc.) to convert a portion of Spectrum A into wavelengths between 580 nm and 700 nm and Spectrum E maybe a AlInGaP red LED emitting between 600 and 800 nm. Infrared emitters or converters may also be add for communication links, security, and night vision applications.

FIG. **18** depicts various shapes of waveguides and luminescent coatings. FIG. **18A** depicts a textured thermally conductive waveguide **203** with a luminescent coating **202**. As an example, a micro lens array maybe be press sintered out of TPA and coated with Ce:YAG via flame spraying. FIG. **18B** depicts an EFG formed single crystal Ce:YAG rod **204** coated with a high emissivity coating **205** with a refractive index substantially equal to the geometric mean of Ce:YAG and air and a thickness greater than 300 angstroms. In the previous example of FIG. **3** the importance of radiative cooling even at low surface temperatures is disclosed. In this example the radiative cooling can represent up to 30% of the total heat dissipated as long as the emissivity of the surface is above 0.8. Emissivity varies from very low (0.01) for polished metals to very high 0.98 for carbon black surfaces. The use of high emissivity coatings **205** that are also transparent in the visible spectrum are most preferred. These include but not limited to

silicates, glasses, organics, nitrides, oxynitrides, and oxides. Even more preferred are high emissivity coating **205** that also exhibit a thermal conductivity greater than 1 W/m/K. The high emissivity coating **205** thickness is preferably between 1000 angstroms and 5 microns thick. The emissivity coating **205** may also be luminescent.

FIG. **19A** depicts a self cooling light source **206** and an optic **207**. Optic **207** may be reflective, transparent, translucent or opaque. Both decorative and directional means may be used as an optic. Parabolic, elliptical, non-imaging and other optical configuration as known in the art may be used as an optic. In particular, the use of prismatic surface elements on optic **207** wherein a substantial portion of the light emitted by self cooling light source **206** are redirected in a direction orthogonal to their original direction are embodiments of this invention. Optic **207** redirects a portion of the light from light source **206** downward. The optic **207** may consist of, but is not limited to, glass, single crystal, polymer or other translucent/transparent materials. Colored translucent/transparent materials create a specific decorative or functional appearance. As an example a light source **206** may be embedded into an orange glass glob to form a decorative lamp. The elimination of the need for a heatsink greatly simplifies the optical design and allows for a wider range of reflectors and optical elements.

Alternately, FIG. **19B** depicts an external movable reflector **209** which slides **210** up and down light source **208**. Using this approach the percentage of downward light can be adjusted relative to the amount of diffuse lighting. Again the elimination of heatsinks and the formation of an extended source greatly simplifies the optical design of the light fixture.

FIG. **20** depicts methods of adjusting the far field distributions of single light sources. In FIG. **20A**, the far field distribution both intensity and wavelength can be adjusted by mounting methods for the LEDs **214** and **216** within or onto wavelength conversion element **211**. LED **214** depicts an embedded LED **214** in which a pocket or depression is formed in wavelength conversion element **211**. This embedded LED changes the ratio of transmitted rays **212** to waveguided rays **213** relative to surface mounted LED **216** which has a substantially different ratio of transmitted rays **217** to waveguided rays **218**.

In FIG. **20B** an optic **220** extracts light off of more than one surface of light source **219**. In this case, rays **221** are redirected substantially orthogonally to the surface the rays were emitted from and mixed with the rays from other surfaces of light source **219**. The optic **220** may be a prism, lens, parabolic, elliptical, aspherical, or free formed shape.

FIG. **20C** depicts embedded LEDs **225** in embedded occlusions **226** with edge-turning elements **224** which were previously disclosed. Rays **227** and **223** can be directed substantially orthogonally out of the wavelength conversion element **222**.

FIG. **21A** depicts a LED die **230** bonded into a wavelength conversion element containing depressions or pockets **228** using a bonding layer **229**, a electrical interconnect layer **231** and protective dielectric layer **232**. As an example, a 500 microns thick Ce:YAG single crystal wafer is laser drilled to have a pocket into which lateral LED die **230** is placed and bonded using a polysilazane. The polysilazane is at least partially cured. The polysilazane is further coated using inkjet printing techniques to cover all but the metal contact pads of lateral LED die **230**. Conductive ink is printed via, but not limited to, inkjet, screenprinting, tampo, or lithographic means such that the exposed metal contact pads of lateral LED die **230** are interconnected electrically via electrical interconnect layer **231**. Nanosilver, silver paste, and other

highly reflective printable electrically conductive inks, pastes or coatings are the preferred conductive ink. A protective dielectric layer **232** is applied via, but not limited to, inkjet, spin coating, dip coating, slot coating, roll coating and evaporative coating means.

FIG. **21B** depicts LED **233** mounted to the surface of waveguide **234** most of the rays do not couple to the waveguide efficiently. FIG. **21C** depicts embedded LED **235** within a pocket in waveguide **236**. Optically and thermally there is more coupling into waveguide **236**. In addition the use of embedded LED **235** allows for simplified interconnect as depicted in FIG. **21A**. Further luminescent insert **237** may be used to convert at least a portion of the spectrum from LED **233** or **235**. In this case lower cost materials may be used for waveguide **234** and **236** respectively. As an example, single crystal Ce:YAG inserts 50 microns thick with a Ce doping concentration greater than 0.2% with substantially the same area as embedded LED **235** can be inserted into press sintered TPA waveguides. In this manner, the amount of luminescent material can be minimized while still realizing the benefit of a thermally conductive element including, but not limited to, waveguide, increased thermal cooling surface, and optical spreading of the light over an area larger than either luminescent insert **237** or LED **235**. Ceramic, polycrystalline, amorphous, composite and pressed powders of luminescent materials may be used for luminescent insert **237**. A waveguide **236** with a thermal conductivity greater than 1 W/m/K can work with a luminescent insert **237**. LED **235** consists of one or more of the LED which is an InGa_N, AlGa_N, and/or AlInGaP based LED in waveguide **236** with a thermal conductivity greater than 1 W/m/K with at least one luminescent insert **237**.

While the invention has been described in conjunction with specific embodiments and examples, it is evident to those skilled in the art that many alternatives, modifications and variations will be evident in light of the foregoing descriptions. Accordingly, the invention is intended to embrace all such alternatives, modifications and variations that fall within the spirit and scope of the appended claims.

The invention claimed is:

- 1.** A self cooling light source comprising a light emitting diode, and a thermally conductive luminescent element on said light emitting diode, said thermally conductive luminescent element being a thermal spreading element for heat generated by said light emitting diode and said thermally conductive luminescent element, and said thermally conductive luminescent element being a light extraction means for light emitted by said light emitting diode.
- 2.** The self cooling light source of claim **1** further comprising wire bonds to provide electrical interconnects for said light emitting diode, and a transparent/translucent bonding layer bonding said wire bonds to said thermally conductive luminescent element, said transparent/translucent bonding layer conducting heat generated by said light emitting diode and said thermally conductive luminescent element and said transparent/translucent bonding layer being a light extraction means for light emitted by said light emitting diode.
- 3.** The self cooling light source of claim **2** wherein said transparent/translucent bonding layer is glass frit, polysiloxane, polysilazane, silicone, and other transparent/translucent adhesive materials.
- 4.** The self cooling light source of claim **1** wherein said thermally conductive luminescent element is single crystal

luminescent materials, polycrystalline luminescent materials, amorphous luminescent materials, thermally conductive transparent/translucent materials such as Sapphire, TPA, Nitrides, Spinel, cubic zirconia, quartz, and glass coated with a thermally conductive luminescent coating.

- 5.** The self cooling light source of claim **1** further comprising a high emissivity layer on said thermally conductive luminescent element, said high emissivity layer enhancing radiative cooling of heat generated by said light emitting diode and said thermally conductive luminescent element.
- 6.** The self cooling light source of claim **5** wherein said high emissivity layer is glass frit, polysiloxane, polysilazanes, flame sprayed ceramics, and evaporative/CVD coatings.
- 7.** The self cooling light source of claim **5** wherein said high emissivity layer is reflective to provide directionality to light emitted by said light emitting diode.
- 8.** The self cooling light source of claim **5** wherein light emitted by said light emitting diode is emitted from both sides of said self cooling light source.
- 9.** The self cooling light source of claim **1** further comprising two thermally conductive luminescent elements, said light emitting diode being partially or fully embedded in said two thermally conductive luminescent elements.
- 10.** The self cooling light source of claim **1** further comprising two light emitting diodes, said two light emitting diodes being partially or fully embedded in said thermally conductive luminescent element.
- 11.** The self cooling light source of claim **5** wherein in said thermally conductive luminescent element is Ce:YAG or a polycrystalline alumina with a thermally fused layer of Mn doped Strontium Thiogallate and a layer of Eu doped Strontium Calcium Sulfide within a glass frit matrix.
- 12.** The self cooling light source of claim **5** wherein said thermally conductive luminescent element is a translucent reflector.
- 13.** The self cooling light source of claim **1** further comprising additional cooling means of heatpipes, metals, glass, ceramics, or plastics to conduct heat generated by said light emitting diode and said thermally conductive luminescent element and to diffuse, reflect or absorb light emitted by said light emitting diode.
- 14.** The self cooling light source of claim **1** further comprising electrical interconnects for said light emitting diode, said electrical interconnects formed by printing and lithographic means, and a transparent/translucent bonding layer connecting said electrical interconnects to said thermally conductive luminescent element, said transparent/translucent bonding layer conducting heat generated by said light emitting diode and said thermally conductive luminescent element and said transparent/translucent bonding layer being a light extraction means for light emitted by said light emitting diode.
- 15.** The self cooling light source of claim **14** wherein said electrical interconnects are a transparent/translucent dielectric layer.
- 16.** The self cooling light source of claim **14** wherein said electrical interconnects are silver conductive inks or thick film silver inks.
- 17.** The self cooling light source of claim **14** wherein said electrical interconnects are partially or fully covered by a transparent/translucent overcoat to environmentally isolate or electrically isolate said self cooling light source.

18. The self cooling light source of claim 14 further comprising a luminescent layer on said transparent/translucent bonding layer.

19. The self cooling light source of claim 14 further comprising multiple self cooling light sources to create uniform illumination in the far field.

20. The self cooling light source of claim 1 wherein said light emitting diode is substrate free.

21. The self cooling light source of claim 1 wherein said thermally conductive luminescent element is non-flat, hemispheric in shape, curved in shape or rectangular saw tooth in shape.

22. The self cooling light source of claim 14 further comprising silver electrical interconnects on a TCO transparent/translucent bonding layer.

23. The self cooling light source of claim 1 further comprising an outer coating covering the ends of said self cooling light source to change the far field distribution of light emitted by said light emitting diode.

24. The self cooling light source of claim 1 wherein said outer coating is a scattering element of metal, diffuse scatterer, dielectric mirror, or translucent material within a matrix.

25. The self cooling light source of claim 23 wherein said self cooling light source has the shape of a candle flame and wherein said outer coating is spectrally variable such that red wavelengths are emitted more readily near the tip of said candle flame and blue wavelengths are emitted more readily near the base of said candle flame.

26. The self cooling light source of claim 1 wherein the active region of said light emitting diode for emitting light is non-square or rectangular in shape.

27. The self cooling light source of claim 1 further comprising a bonding layer between said light emitting diode and said thermally conductive luminescent element for bonding said light emitting diode to said thermally conductive luminescent element.

28. The self cooling light source of claim 1 wherein said thermally conductive luminescent element is a wavelength conversion element for light emitted by said light emitting diode.

29. The self cooling light source of claim 28 further comprising
a red emitting light emitting diode and
a blue emitting light emitting diode, said self cooling light source emitting light of a range of wavelengths.

30. The self cooling light source of claim 28 further comprising multiple light emitting diodes emitting multiple different colors of light.

31. The self cooling light source of claim 28 further comprising
two different color emitting light emitting diodes and
a barrier between said two different color emitting light emitting diodes, said barrier thermally isolating and electrically isolating said two different color emitting light emitting diodes, said self cooling light source being a dual color light source.

32. The self cooling light source of claim 28 wherein said thermally conductive luminescent element has Ce:YAG phosphor, said self cooling light source being a white light source.

33. The self cooling light source of claim 29 wherein self cooling light source being a white light source.

34. The self cooling light source of claim 1 wherein said thermally conductive luminescent element is a waveguide for light emitted by said light emitting diode.

35. The self cooling light source of claim 1 further comprising an optic to redirect light emitted by said light emitting diode.

36. The self cooling light source of claim 1 wherein said optic is an external moveable reflector.

37. The self cooling light source of claim 1 wherein the depth of embedding said light emitting diode in said thermally conductive luminescent element adjusts the far field distributions of light emitted by said light emitting diode.

38. A self cooling light source comprising
a light emitting diode, and
a thermally conductive wavelength conversion element on said light emitting diode, said thermally conductive wavelength conversion element being a thermal spreading element for heat generated by said light emitting diode and said thermally conductive wavelength conversion element, and said thermally conductive wavelength conversion element converting the wavelength of light emitted by said light emitting diode.

39. A self cooling solid state light source, comprising:
at least one light-emitting diode (LED) die; and
at least one thermally conductive luminescent element, wherein said luminescent element includes an electrical interconnect and functions as a wavelength converter, converting at least a portion of the light emitted by said LED die to a different wavelength range, and also functions as an optical waveguide for light emitted by said LED die, and also functions as a heat spreading element, spreading heat generated by said LED die over a greater cross-sectional area, and finally provides a high emissivity layer, for optimal coupling of emitted light from the light source.

40. A self cooling solid state light source as defined in claim 39, wherein said at least one thermally conductive luminescent element also functions as a device substrate.

41. A self cooling solid state light source as defined in claim 39, wherein said self cooling solid state light source further comprises an external interconnect.

42. A self cooling solid state light source as defined in claim 39, wherein said self cooling solid state light source further comprises an environmental enclosure for said LED die.

43. A self cooling solid state light source, comprising:
at least one light-emitting diode (LED) die; and
at least one thermally conductive luminescent element bonded to the at least one LED die;
wherein light is emitted from the LED die principally in a direction through the at least one luminescent element, and heat generated in the light source is transmitted principally in the same direction as the direction of light emission, whereby heat is dissipated from the light source by a combination of radiation, conduction and convection from the at least one luminescent element, without the need for a device heat sink.

44. A self cooling solid state light source as defined in claim 43, wherein the at least one luminescent element is bonded to the LED die by a bonding layer with high thermal conductivity.

45. A self cooling solid state light source as defined in claim 44, and further comprising a high emissivity layer formed on the at least one luminescent element.

46. A self cooling solid state light source as defined in claim 43, wherein the thermally conductive luminescent element functions as a wavelength converter, an optical waveguide, a heat spreader and a device substrate.